

since
1926

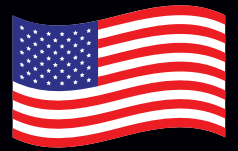

Proudly made in the USA



CUTTING TOOL STORAGE

FOR DRILLS, TAPS, END MILLS, REAMERS, TOOLHOLDERS, COLLETS & MORE

Since 1926, a commitment to you, our customer.

Nearly a century ago, Gene Huot (pronounced “Hewitt”) invented and marketed the Drill Index, a method of storing and organizing often used drill bits, making their use quicker and more efficient. This simple but significant industry breakthrough has withstood the test of time.

Since the introduction of the index, Huot has increased its product offering to include similar products for storing all types of cutting tools used in a shop or production environment. As technology changed and tooling changed with it, Huot answered the call by designing and building storage and organization solutions for just about every type of tool being used by precision metal workers every day.

The products in this catalog are designed to make your shop environment more organized, efficient, clean, and ultimately, more profitable. Efficiency leads to cost savings, and time is money in a production operation. Each of our products is quality made to the highest standards of excellence, built with American pride. Only in this way can we earn your complete satisfaction and maintain your continued trust in our products. Thank you for taking the time to explore our storage solutions; we’d be honored to be a part of your operation’s success.

Huot Manufacturing, we’re family owned and American made.

5S Initiatives – What are they and why use them?

We’ve all heard the term “5S”, but what is it and how does it work? In an effort to be more competitive globally, in the 1960’s a Japanese company developed 5S methods to cut costs, increase efficiency, quality and profitability. Expanding on lean initiatives, this benchmark for quality programs is used by companies around the world. These simple ideas were developed for manufacturing purposes but can improve efficiency anywhere you apply them.

Here are the 5S words and their meanings:

SORT – Determine what is needed for an area and remove what isn’t.

SET (in order) – Designate a place for everything in the area, and keep it there when not in use.

SHINE – Always keep the area clean and organized.

STANDARDIZE – Make all similar areas visually the same with efficiency and organization in mind.

SUSTAIN – Ensure initiatives are being followed being followed at all times.

Other “S’s” were Safety and Security, but the developers wanted to keep it simple so they kept it at 5. After Covid, we though Sanitize would be another good “S”, so we developed products that will help you meet your 5, 6, 7, and even 8S initiatives. **If you are thinking 5S, think Huot.**

Cuttings tools, wrenches and toolholders shown throughout this catalog are for pictorial use only and are not included with any Huot products.

SCOOTS

ToolScoot™	3
SuperScoot	7
ToolScoot™ Tree	10-13
TriScoot	4
SpeedyScoot	6
Custom Scoots	4
ToolScoot™ Ltd	6
ShieldScoot	5
SecurityScoot	5
UltraScoot, UltraScoot II	7-8
LatheScoot	9
UtilityScoot	9

SAFETY COVERS

SAFETY COVERS	3
---------------	---

VICES FOR TOOLHOLDERS

VICES FOR TOOLHOLDERS	3
-----------------------	---

COLLETS

ER/RD/DA/DR/TG Racks	11-14, 19, 20
Swiss Collet Racks	11-14, 15, 19, 20
Quick Change Collets	11-14, 18, 19
5C, 16C, 20C, 3J, R8	3, 4, 11, 17, 22, 23

WORKSTATIONS

WORKSTATIONS	15
--------------	----

FRAMEWORK for existing tables

FRAMEWORK for existing tables	16
-------------------------------	----

TOWERS

SuperTower	17
ToolTower	17

WALL MOUNTABLE

Machine or Wall Mount Racks	14, 21, 22
-----------------------------	------------

BENCH TOP

Platforms, Racks	22-23
------------------	-------

LOCKERS

Tall Locker & Wall Locker	14
---------------------------	----

DRILL DISPENSERS

Fractional	24, 27, 28
Wire	24, 27, 28
Letter	24, 27, 28
Silver Deming	24, 27
Taper Shank/Length	27
Step Drill	25
Metric	24, 25, 27, 28

TAP DISPENSERS, TAP & DRILL DISPENSERS

TAP DISPENSERS, TAP & DRILL DISPENSERS	24, 25, 28
--	------------

BURR DISPENSER

BURR DISPENSER	26
----------------	----

END MILL DISPENSERS, REAMER DISPENSERS

END MILL DISPENSERS, REAMER DISPENSERS	26, 28, 29
--	------------

INSERT DISPENSERS, UNIVERSAL DISPENSER

INSERT DISPENSERS, UNIVERSAL DISPENSER	29, 30
--	--------

SUPER CABINET, SUPER CHEST

SUPER CABINET, SUPER CHEST	31
----------------------------	----

MEASURING TOOLS DISPENSER

MEASURING TOOLS DISPENSER	30
---------------------------	----

MASTER DISPENSER STANDS

MASTER DISPENSER STANDS	30
-------------------------	----

INDEXES & STANDS

Bit Buddy Drill Index	33
Drills	32-35
Reamer, Screw Extractor	32
Stub/Screw Machine Length, Taper Shank/Taper Length	34
Silver Deming	34
Carbine Burrs	34
Tap, Tap & Drill	35
Metric	32-35
Stands, Drill Gauges	35-36

DROP IN DRAWER INSERTS

DROP IN DRAWER INSERTS	23
------------------------	----

CAN RACK, SPRAY BOTTLE RACKS

CAN RACK, SPRAY BOTTLE RACKS	37
------------------------------	----

PAPER HOLDERS/WEBBING

PAPER HOLDERS/WEBBING	38
-----------------------	----

ToolScoot™

- The "Original" toolholder cart
- Constructed of 16 gauge steel for normal use
- Swivel and locking casters rated for 1000 lbs
- Molded inserts hold toolholders and protect tapers
- Angled lower shelf provides easy access from both sides
- Lower shelf has multiple height adjustments
- End trays can be mounted on either side, or both sides on top
- Steel finished in a baked on, durable, red & black powder coating
- Requires assembly



EDP #13940

EDP#	Description 18" W x 35.25" L x 35" H, 75 lbs	Capacity
13930	BT, CAT, NMTB 30 taper	48
13940	BT, CAT, NMTB 40 taper	48
13949	HSK 40A, 40C, 40E and KM40 tapers	48
13950	BT, CAT, NMTB 50 taper	36
13955	16C collets	100
13960	5C collets	96
13965	R8 collets or #4 Morse Taper	96
13970	HSK 63A taper	48
13980	HSK 100A taper	36
13984	CAPTO® C4 taper	48
13985	CAPTO® C5 taper	48
13986	CAPTO® C6 taper	48

CAPTO® is a registered trademark of Sandvik AB



Scan for
YouTube video



Safety Covers

- Protects operator from injuries and allows for tool visibility
- Keeps tools safe and clean during storage
- Covers held in place with twist in key hold slots molded into base
- Shoulder bolts for mounting covers included
- Dry markers can be used for labeling tools or jobs
- Proprietary to Huot red shelves



Scan for
YouTube video

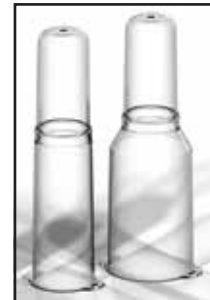

EDP#	Description 14" H, 0.5 lbs	Dimensions
14001	Clear - 30, 40, HSK 63A, HSK 40A, C4, C5, C6 tapers	Base inside dimension is 3.150", at the top 2.500", height is 13.375"
14016	Clear - 50 or HSK 100A tapers	Base inside dimension is 4.375", at the top 2.750", height is 14.000"

Toolholder Vises

Toolholder Vises

- Mounts vertically or horizontally
- Handle locks tool for access to pull stud or collet simultaneously
- Durable aluminum construction
- Pre-drilled mounting holes
- Use fasteners with a 3/8-16 thread at least 1.25" long to fasten vises to a Huot Workstation
- Great value price point
- Measures 6" L x 4½" W x 5½" H

EDP#	Description 3.5 lbs
50523	CAT 30
50524	BT 30
50525	CAT 40
50526	BT 40
50527	CAT 50
50528	BT 50
50563	HSK 63A, 63F, KM 63



EDP #50525

TriScoot

- Taller chassis sides provide for 3 shelves
- 33% more storage capacity within a Toolscoot footprint
- Multiple tapers and collet shelves available
- Mix and match tapers and collets on a single Scoot
- TriScoot chassis is the basis for custom Scoots (see below)
- Chassis provides for 7 different shelf mounting positions
- Requires assembly



EDP #13409

EDP#	Description 18" W x 20.25" L x 41" H, 75 lbs	Cap.
13309	BT, CAT, NMTB 30 taper	72
13409	BT, CAT, NMTB 40 taper	72
13509	BT, CAT, NMTB 50 taper	54
13773	CAPTO® C3 taper	72
13774	CAPTO® C4 taper	72
13775	CAPTO® C5 taper	72
13776	CAPTO® C6 taper	72
13778	CAPTO® C8 taper	54
13916	3J collets	72
13962	HSK 100A taper	54
13963	KM63 or HSK63A taper	72
13964	HSK 40A taper	72
13968	HSK 63F taper	72
13993	#30 VDI taper	72
13994	#40 VDI taper	72
14865	Optional Side Tray	N/A
77332	32MM Quick Change collets	54
77342	42MM Quick Change collets	54
77352	52MM Quick Change collets	54
77365	65MM Quick Change collets	45
77380	80MM Quick Change collets	39
77399	100MM Quick Change collets	30

Custom Scoot

Have a unique taper machine or some oddball tooling that won't fit in our molded inserts? We can build a custom scoot based on the TriScoot chassis above. Instead of using a molded insert to hold the tools, we will machine an unbreakable High Density Poly Ethylene (HDPE) top that will act as an insert to protect the tools while the typical hole pattern in the steel shelf will support the weight underneath. The holes will be custom milled to match the D1 dimension of your tools (see diagram) for a snug, secure fit. Just provide the D1 dimension of the tool and we will take it from there. We build these all day, every day, for unique tapers and collets. Call or email us today for more information, and we will build one for you too.

EDP #13914 24 holes per shelf, 2¼" maximum D1 dimension, total capacity of 72

EDP #13915 18 holes per shelf, 3¼" maximum D1 dimension, total capacity of 54

Call for anything larger than a 3¼" D1 dimension

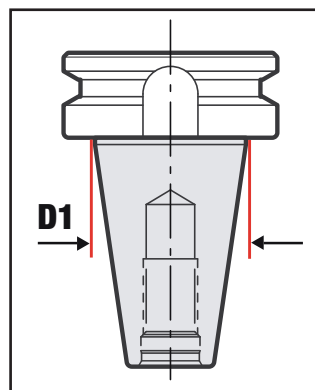

EDP #13915



SecurityScout

- Lockable polycarbonate doors keep tools clean and secure
- Doors are keyed alike for easy operation
- Clear panels allow for easy tool identification
- Two full toolholder shelves provide good capacity
- Upper and lower cam locks keep doors securely closed
- Magnets hold doors closed when unlocked
- Full length piano style hinges on all doors
- Adjustable positions for mounting shelves
- Ideal for pre-set jobs waiting to be loaded
- Keeps tools clean in a dirty shop environment
- Full assembly is required

EDP#	Description 41" H x 35" W x 20" D, 130 lbs	Capacity
16930	BT, CAT, NMTB 30 taper	48
16940	BT, CAT, NMTB 40 taper	48
16950	BT, CAT, NMTB 50 taper	36
16964	HSK 40A, 40C, 40E and KM40 tapers	48
16970	HSK 63A taper	48
16980	HSK 100A taper	36
16984	CAPTO® C4 taper	48
16985	CAPTO® C5 taper	48
16986	CAPTO® C6 taper	48
16988	CAPTO® C8 taper	36



EDP #16940

ShieldScout



EDP #14940



- No toolholders with exposed sharp tools on top
- Access toolholders through open top doors and/or from the sides
- Top doors open on full length hinges front and rear
- Top doors open one or both at a time
- Flat shelves keep tools within chassis
- Two full shelves provide good capacity
- Safety covers can also be used on shelves for added protection
- Compliant in shop safety initiatives
- Keeps tools safer and cleaner
- Requires assembly

EDP#	Description 42.75" H x 27.5" W x 18.5" D, 82 lbs	Capacity
14930	BT, CAT, NMTB 30 taper	48
14940	BT, CAT, NMTB 40 taper	48
14950	BT, CAT, NMTB 50 taper	36
14964	HSK 40A, 40C, 40E and KM40 tapers	48
14970	HSK63A taper	48
14980	HSK100A taper	36
14984	CAPTO® C4 taper	48
14985	CAPTO® C5 taper	48
14986	CAPTO® C6 taper	48
14988	CAPTO® C8 taper	36

CAPTO® is a registered trademark of Sandvik AB

EDP#	Description	41" W x 35.25 H x 18" D	Capacity
13630	BT, CAT, NMTB 30 taper		24
13640	BT, CAT, NMTB 40 taper		24
13655	BT, CAT, NMTB 50 taper		18
13664	HSK 40A, 40C, 40E & KM40 tapers		24
13670	HSK 63A taper		24
13680	HSK 100A taper		18
13684	CAPTO® C4 taper		24
13685	CAPTO® C5 taper		24
13686	CAPTO® C6 taper		24
13688	CAPTO® C8 taper		18

- Toolholder top shelf available in most popular tapers
- 2" drawer has welded columns & adjustable dividers
- Open 6" drawer has dual slides for larger weight capacity
- Welded chassis adds strength and rigidity
- Side tray holds Huot collet racks, or miscellaneous tools
- Ideal for special ops applications
- Minimal assembly required, bolt on casters
- Ships LTL only



EDP #13640



Interior view of top drawer

SpeedyScoot

- At only 15" wide, the SpeedyScoot was designed for small shops with narrow aisles and tight corners between machines
- Available in all popular tapers

- Often used in tool rooms to preset small jobs in a dedicated scoot for a job or machine
- Rugged steel construction, heavy duty 4" caster rated for 1000 lbs

- Multiple middle shelf options, recommended for productivity and stability
- Requires assembly



EDP #33940

EDP#	V-Flange & HSK SpeedyScoot	15" W x 30" L x 35" H, 52 lbs	Capacity
33930	BT, CAT, NMTB 30 taper		24 ¹
33940	BT, CAT, NMTB 40 taper		24 ¹
33944	CAPTO® C4 taper		24 ¹
33945	CAPTO® C5 taper		24 ¹
33946	CAPTO® C6 taper		24 ¹
33950	BT, CAT, NMTB 50 taper		15 ¹
33964	HSK 40A, 40C, 40E and KM40 tapers		24 ¹
33970	HSK 63A taper		24 ¹
33980	HSK 100A taper		15 ¹

1. Double tooling capacity with optional second shelf (see below).

SpeedyScoot Middle Shelf Options

EDP#	SpeedyScoot Accessories	15" W x 30" L, 6 lbs	Capacity
14130	BT, CAT, NMTB 30 taper		24
14134	CAPTO® C4 taper		24
14135	CAPTO® C5 taper		24
14136	CAPTO® C6 taper		24
14164	HSK 40A, 40C, 40E and KM40 tapers		24
14170	BT, CAT, NMTB 40 taper		24
14175	BT, CAT, NMTB 50 taper		15
14180	HSK 63A taper		24
14185	HSK 100A taper		15
14190	2nd shelf flat storage		N/A



EDP #14170

SuperScoop™



EDP #23940



- Constructed of heavy duty 12 gauge steel for rugged use
- Ideal for larger size tapers
- Casters load rated to 1600 lbs
- Maximized storage per square foot for larger capacities
- Outrigger design for added stability
- Shelves present tools at a 13° angle
- Gold vein powder coated finish
- Assembly required

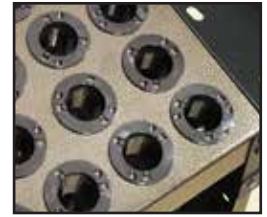

Scan for
YouTube video

EDP#	Description 45.25" W x 17.5" D x 40" H, 132 lbs (width includes handle & tray)	Capacity
23940	BT, CAT, NMTB 40 taper	90
23950	BT, CAT, NMTB 50 taper	52
23964	HSK 40A, 40C, 40E and KM40 tapers	90
23970	HSK 63A taper	90
23980	HSK 100A taper	52
23984	CAPTO® C4 taper	90
23985	CAPTO® C5 taper	90
23986	CAPTO® C6 taper	90

UltraScoop II

- An UltraScoop cut in half
- For larger toolholders & capacities
- 12 gauge steel construction
- Lower shelf deep in chassis best for storing long gage tools in toolholders
- Shelves can be mounted in 11 positions in chassis
- Sturdy MIG welded frame
- Outrigger design for added stability
- UltraScoop casters load rated to 4800 lbs
- Side tray and handle
- Minimal assembly required, bolt on casters
- Ships LTL only

EDP#	Description 45" W x 42" H x 26" D, 127 lbs	Capacity
99740	BT, CAT, NMTB 40 taper	88
99750	BT, CAT, NMTB 50 taper	60
99760	BT, CAT, NMTB 60 taper	32
99764	HSK 40A, 40C, 40E and KM40 tapers	88
99770	HSK 63A taper	88
99780	HSK 100A taper	60
99725	HSK 125A taper	48
99784	CAPTO® C4 taper	88
99785	CAPTO® C5 taper	88
99786	CAPTO® C6 taper	88
99788	CAPTO® C8 taper	60



EDP #99750

CAPTO® is a registered trademark of Sandvik AB



EDP #99940



Scan for additional details



- Primarily designed for CAT 60 or HSK 125A tapers
- Can be configured for smaller tapers too; see huge capacity figures in chart
- Small and large taper shelves can be configured together
- Made from heavy duty 12 gauge cold rolled steel
- MIG welded chassis for ultimate strength and durability
- Shelves have 11 mounting positions per side
- Six caster configuration load rated to 7200 lbs
- Outrigger chassis design for added stability
- Often used for bi-annual machine maintenance - empty machine's carousel into a single Scout
- Minimal assembly required, bolt on casters
- Ships LTL only

EDP#	Description 75.25" W x 42.25" H x 29.75" D, 254 lbs (Width includes handle & tray. Ships LTL.)	Capacity
99940	BT, CAT, NMTB 40 taper	176
99950	BT, CAT, NMTB 50 taper	120
99960	CAT 60 taper	64
99964	HSK 40A, 40C, 40E and KM40 tapers	176
99970	HSK 63A tapers	176
99980	HSK 100A taper	120
99125	HSK 125A taper	96
99984	CAPTO® C4 taper	176
99985	CAPTO® C5 taper	176
99986	CAPTO® C6 taper	176
99988	CAPTO® C8 taper	120
EDP#	Accessories	
14899	Extra side shelf (1 is included)	



CAPTO® is a registered trademark of Sandvik AB

LatheScoot

EDP #77300

- Unique - specifically designed for turning operations
- Deep, sturdy, removable and dividable bins organize set up tools on top
- Top 2" drawer utilizes welded columns/dividers for tool organization
- Dual slide, deep large 6" drawer, ideal for live tooling heads and larger tools
- Welded chassis adds strength and rigidity
- Large open area on bottom for 3 jaw chucks or collet chucks
- Huot collet racks fit handily into side tray
- Live/Dead center shelf on the bottom in 3MT & 4MT
- Dimensions: 41" L x 35¼" H x 18" D
- Minimal assembly required, bolt on casters



Scan for
YouTube video



EDP #77300

The only Scoot designed specifically with lathe tooling in mind

Have the same job come into your shop repeatedly? Buy extra bins (EDP # 33166), and use our divider kit (77030) to create customizable compartments, then prepare the tools for the job in the bins. Store the bins somewhere handy and when that job comes in, simply remove the existing ones, drop the pre tooled ones into place, wheel the Scoot over to the machine and you're making parts! Reduce set up time dramatically. Alkro-Mils sells a snap on lid for the bin (33601) to keep things clean, secure and identifiable.



EDP #33166



EDP #77030



EDP #33601

UtilityScoot



EDP #16800

EDP #16800

- Cold rolled steel construction for long lasting performance
- Replace crumbling resin carts
- Made with the same quality you would expect from Huot ToolScoots™
- Tub depth of trays is 2¼"
- Adjustable lower shelf positions
- Locking and swivel casters
- 1000 lbs weight capacity
- Dimensions: 27¼" L x 32¼" H x 18¼" D
- Assembly required



Proudly made
in the USA

What is the Tree Family of Shelves?

Our popular ToolScoot™ Tree offers great storage capacity and versatility. You will find other products in this catalog that use the “Tree Family of Shelves.” What is the “Tree Family of Shelves?” The ToolScoot™ Tree chassis has two long columns of slots along the length of the chassis (yellow arrows). The Tree shelves fit into slots at different heights on the chassis, according to where the user desires the shelf to be.

The angled shelf presents the tools nicely and creates a sight line from across the shop to help identify what is in the shelves. Huot Manufacturing uses the Tree Family of Shelves in several other products creating a modular system that allows you to use whatever types of tools you are storing anywhere you need them - at one machine, at a different machine, in the Tool Crib, wherever those tools are needed.

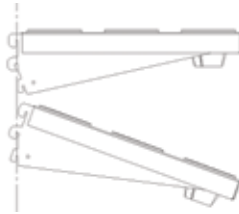

Side View

The top 2 tabs on the back of the Tree shelves are used to mount the shelf flat



The bottom 2 tabs mount the shelves at a -20° angle

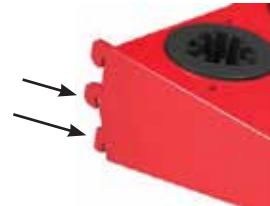

Other Huot Products that use the Tree Family of Shelves



Tall Locker (page 14)



Wall Locker (page 14)



Wall Tree Mount (page 14)



Worktable Framework (page 16)



Shown with
55150,
55110,
and 79236

Workstation Back Rack (page 15)

Available Tree Family Shelves, custom shelves also available

EDP#	Description	Capacity
55100	Tool Storage Box, no Dividers	N/A
55105	Tool Storage Box, with Dividers	N/A
55110	Utility Shelf	N/A
55114	18 Hole Custom Shelf	18
55115	10 Hole Custom Shelf	10
55140	BT, CAT, NMTB 40 taper	18
55150	BT, CAT, NMTB 50 taper	10
55155	16C collets	36
55164	HSK 40A taper	18
55170	HSK 63A taper	18
55173	R8 collets	50
55174	5C collets	50
55176	HSK 63F taper	18
55180	HSK 100A taper	10
55183	CAPTO® C3 taper	18
55184	CAPTO® C4 taper	18
55185	CAPTO® C5 taper	18
55186	CAPTO® C6 taper	18
55188	CAPTO® C8 taper	10
55193	VDI 30 taper	18
55194	VDI 40 taper	18
55232	32MM Quick Change collets	17
55242	42MM Quick Change collets	17
55252	52MM Quick Change collets	17
55265	65MM Quick Change collets	12
55280	80MM Quick Change collets	8
55299	100MM Quick Change collets	6



Toolholder Shelf



Collet Shelf



Utility Tray



Quick Change Collet Shelf



Tool Storage Box with Dividers



Standard ER Collet Racks in Utility Shelf

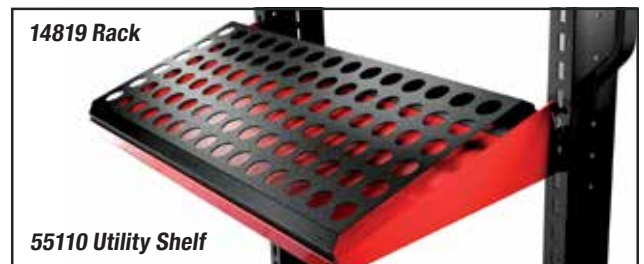

14819 Rack

55110 Utility Shelf

Large ER and Swiss Collet Racks in Utility Shelf

ToolScoot™ Tree - Standard Chassis

- Slotted uprights provide 35 possible shelf locations on each side of cart (70 total)
- Welded 14 gauge unibody chassis with see through design
- Includes 6 shelves - 5 for toolholders and 1 for utility
- Other shelf configurations available
- Molded inserts protect and securely hold toolholders
- Every 5th slot marked for easy shelf positioning
- Shelves can be positioned flat or at a -20° angle
- 16 gauge steel shelves for strength and rugged durability
- Casters are load rated to 1,600 pounds
- Heavy duty 5" casters - two swivel with brakes and two stationary

EDP#	Description	28.5" W x 57" H x 28" D, 135 lbs	Cap.
55930	BT, CAT, NMTB 30 taper		90
55940	BT, CAT, NMTB 40 taper		90
55950	BT, CAT, NMTB 50 taper		50
55964	HSK 40A, 40C, 40E and KM40 tapers		90
55970	HSK 63A taper		90
55980	HSK 100A taper		50
55984	CAPTO® C4 taper		90
55985	CAPTO® C5 taper		90
55986	CAPTO® C6 taper		90
55988	CAPTO® C8 taper		50

CAPTO® is a registered trademark of Sandvik AB



Scan for
YouTube video



Proudly made
in the USA



Utility shelf comes standard with each Tree. We have created large ER and Swiss collet racks designed to fit perfectly in this shelf. Please see page 20 for details.

ToolScoot™ Tree - Tall Chassis



EDP #55340

- Tall chassis is 12" taller than standard chassis
- Ergonomics, the user chooses comfortable shelf heights
- The tallest tree-type tool storage on the market
- Six shelves are included
- Greater capacity in the same footprint
- Increased spacing between shelves
- Tall chassis height ideal for bringing toolholders to machines with mezzanines



Both chassis sizes have built in peg board for hanging hand tools or accessories



Slotted chassis provides easy storage for spanner wrenches

EDP#	Description 28.5" W x 69" H x 28" D, 149 lbs	Capacity
55330	BT, CAT, NMTB 30 taper	90
55340	BT, CAT, NMTB 40 taper	90
55350	BT, CAT, NMTB 50 taper	50
55364	HSK 40A, 40C, 40E and KM40 tapers	90
55370	HSK 63A taper	90
55380	HSK 100A taper	50
55384	CAPTO® C4 taper	90
55385	CAPTO® C5 taper	90
55386	CAPTO® C6 taper	90
55388	CAPTO® C8 taper	50

CAPTO® is a registered trademark of Sandvik AB



Tall Locker, Wall Locker, Wall Tree



Tall Locker
EDP #55641

- Lockers store tools and protect them from dust, debris and theft
- Unit stands over 6' tall and comes with 5 toolholder shelves
- Uses the Tree family of shelves for toolholders and collets
- Doors have full length hat channels for strength and stability
- Throw bar and lock keeps door closed tight
- Finished in baked on powder coat for lasting durability

EDP#	Description	34.25" W x 16.125" D x 74" H, 210 lbs	Cap.
55631	BT, CAT, NMTB 30 taper		90
55641	BT, CAT, NMTB 40 taper		90
55651	BT, CAT, NMTB 50 taper		50
55664	HSK 40A, 40C, 40E and KM40 tapers		90
55671	HSK 63A taper		90
55681	HSK 100A taper		50
55684	CAPTO® C4 taper		90
55685	CAPTO® C5 taper		90
55686	CAPTO® C6 taper		90



Wall Locker
EDP #55741

- Same features as the Tall Locker but only 46½" high
- Designed to mount on a wall or can be used on a bench top
- Ideal for collet storage in a tool crib or machine cell

EDP#	Description	31.25" W x 15.75" D x 46.5" H, 110 lbs	Cap.
55731	BT, CAT, NMTB 30 taper		54
55741	BT, CAT, NMTB 40 taper		54
55751	BT, CAT, NMTB 50 taper		30
55764	HSK 40A, 40C, 40E and KM40 tapers		54
55771	HSK 63A taper		54
55781	HSK 100A taper		30
55784	CAPTO® C4 taper		54
55785	CAPTO® C5 taper		54
55786	CAPTO® C6 taper		54

- Base mounts directly to wall in tool crib, cell, or anywhere toolholders are needed
- Uses the Tree family of shelves
- Open design allows easy identification and access to tools
- Shelves can be mixed and matched for toolholders and collets

EDP#	Description	28.5" W x 36" H x 14" D, 55 lbs	Cap.
55730	BT, CAT, NMTB 30 taper		54
55740	BT, CAT, NMTB 40 taper		54
55750	BT, CAT, NMTB 50 taper		30
55763	HSK 40A, 40C, 40E and KM40 tapers		54
55770	HSK 63A taper		54
55780	HSK 100A taper		30
55790	CAPTO® C4 taper		54
55791	CAPTO® C5 taper		54
55792	CAPTO® C6 taper		54
55797	CAPTO® C8 taper		30



Wall Tree
EDP #55740

Workstation

- Durable hardwood butcher block top with plenty of work space
- Top 2 drawers utilize welded columns with dividers every 1" for customizing storage and organization (see inset photo)
- Larger 4" drawer is open for larger tools & miscellaneous items
- Bottom tooling drawer holds up to 30 toolholders depending on taper size
- Cabinet has threaded holes on both sides for mounting a Huot tool changing vise* horizontally or vertically (shown)
- Use fasteners with a 3/8-16 thread at least 1.25" long to fasten vises to a Huot Workstation
- Locking doors protect against chips & debris and keep valuable tools secure
- All drawers use full extension ball bearing slides
- Cabinet pockets allow for movement with a forklift



EDP #77240

*Vise sold separately

EDP#	Description 34" L x 22.75" W x 39" H, 285 lbs	Capacity
77230	BT, CAT, NMTB 30 taper	30
77240	BT, CAT, NMTB 40 taper	30
77250	BT, CAT, NMTB 50 taper	18
77264	HSK 40A, 40C, 40E and KM40 tapers	30
77270	HSK 63A taper	30
77280	HSK 100A taper	18
79332	32MM Quick Change collets	30
79342	42MM Quick Change collets	30
79352	52MM Quick Change collets	30
79365	65MM Quick Change collets	16
79380	80MM Quick Change collets	16
79399	100MM Quick Change collets	11
79624	CAPTO® C4 taper	30
79625	CAPTO® C5 taper	30
79626	CAPTO® C6 taper	30
79628	CAPTO® C8 taper	30

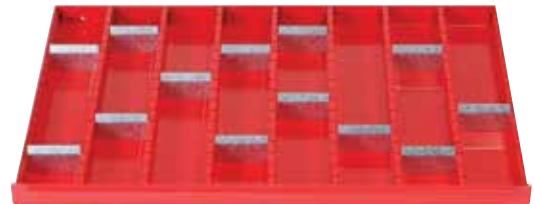

Interior view of top 2 drawers



Scan for
YouTube video



Proudly made
in the USA

CAPTO® is a registered trademark of Sandvik AB

EDP #77277 Work-Surface Extension

- Bolts to either or both ends of the Workstation, doubling or tripling work surface
- Thick wood top makes it an ideal base for a presetter or shrink fit system
- Lower shelf can be mounted in multiple positions for a CPU or chiller
- Plenty of open space for cables and hoses
- Measures 17¾" x 33"



EDP #77277

Workstation Back Rack



Shown with
55150, 55110,
and 79236

EDP #79231 Workstation Back Rack

- Two piece easy install with included hardware
- Made of rugged 24 gauge steel
- 24 shelf position slots per side
- Uses shelves from the Huot Tree Family
- Shelves mount flat or at a -20° angle
- Back lip helps prevent part roll off
- Retains use of tool vises on either side
- Dimensions: 34¼" W x 40½" H

Worktable Framework

- Framework bolts through existing 6 ft wood table top
- Mounting and assembly instructions included
- Framework uses the Tree family of shelves
- Allows for toolholders and collets be stored off table top surface
- Clearboard allows for hanging tools or fixtures
- Frequently used tools can be shadowed on Clearboard
- Ideal for preventing Foreign Object Debris (FOD) damage
- Clearboard allows for better lighting and visibility
- All pieces sold separately
- Multiple shelf height positions
- Measures 56" W x 35" H
- Assembly required

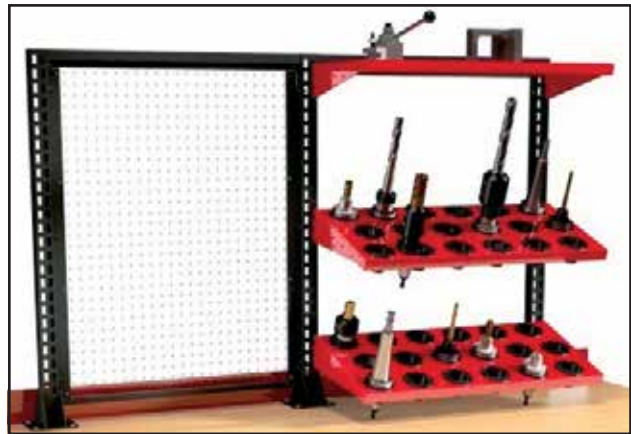

Shown with optional Clearboard and shelves from the Tree family of shelves



EDP #78235



**Proudly made
in the USA**

*Optional
clearboard for
shadowing or
hanging hand
tools*

Bolts to your existing 6' table

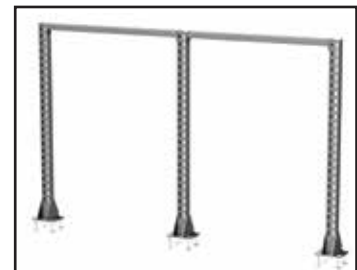

EDP #78230

Workstation/Super Cabinet Side Panel Pegboard



EDP #79236

- 14 gauge steel construction
- Scratch resistant powder paint
- Mounts on either side or rear of cabinet
- Easy installation, done in minutes
- Beveled sides provide sight lines of panel
- Increases product efficiency and use
- Does not affect drawer operation
- Perfect for 5S initiatives
- Economically priced, great value
- Dimensions: 18" W x 3/4" D x 30" H



ToolTower



EDP #13840

- ToolTowers come standard with 3 shelves
- Sturdy 16 ga. steel construction
- Adjustable shelf positions
- Can be stacked to double storage in same footprint
- Stacking kit makes stacking quick, safe and easy
- Molded inserts hold and protect toolholders
- Optional clear doors keep tools clean and secure
- Upper and lower door cam locks keep doors closed tight
- Full length piano style hinges on both doors
- Assembly required



Stacked Tower shown with available EDP #50520 doors

EDP#	Accessories	Weight
14860	Stacking Kit - stack two ToolTowers together	7 lbs
14865	ToolTower Tray	8 lbs
50520	ToolTower Door Set, two required	18 lbs

EDP#	Description	Capacity
13830	BT, CAT, NMTB 30 taper	72
13840	BT, CAT, NMTB 40 taper	72
13850	BT, CAT, NMTB 50 taper	54
13858	20C collets	72
13860	5C collets	150
13864	HSK 40A, 40C, 40E, KM40 tapers	72
13865	R8 or #4 Morse Taper	150
13870	HSK 63A taper	72
13880	HSK 100A taper	54
13884	CAPTO® C4 taper	72
13885	CAPTO® C5 taper	72
13886	CAPTO® C6 taper	72
13888	CAPTO® C8 taper	54
13890	16C collets	150
13893	#30 VDI taper	72
13894	#40 VDI taper	72
77132	32MM Quick Change collets	54
77142	42MM Quick Change collets	54
77152	52MM Quick Change collets	54
77165	65MM Quick Change collets	45
77180	80MM Quick Change collets	39
77199	100MM Quick Change collets	30
13844	All flat shelves, no holes	N/A

CAPTO® is a registered trademark of Sandvik AB

SuperTower

- SuperTowers come standard with 3 shelves
- Constructed of heavy duty 12 gauge steel
- Stackable for doubling storage within same footprint
- Ideal for larger size tapers
- Maximized storage per square foot for larger capacities
- Shelves present tools at a 13° angle
- Gold vein powder coated finish
- Efficient solution for large tool cribs with sizeable storage needs

EDP#	Description	Capacity
23830	BT, CAT, NMTB 30 taper	135
23840	BT, CAT, NMTB 40 taper	135
23850	BT, CAT, NMTB 50 taper	78
23864	HSK 40A, 40C, 40E and KM40 tapers	135
23870	HSK 63A taper	135
23880	HSK 100A taper	78
23884	CAPTO® C4 taper	135
23885	CAPTO® C5 taper	135
23886	CAPTO® C6 taper	135
EDP#	Accessories	Weight
24860	Stacking Kit - stack 2 SuperTowers together	10 lbs



EDP #23850

- Tower is stackable two high to expand your storage area (see illustration)
- Assembly required

CAPTO® is a registered trademark of Sandvik AB

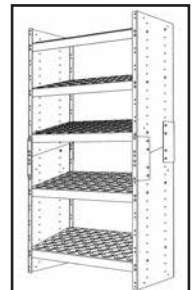

Quick Change Collet Solutions

- Constructed of 16 gauge steel
- Casters on Scoot provide portability
- Mix and match sizes on scoot
- Platform displays collets on a 13° angle
- For all quick change collet sizes
- Tree family shelves available



EDP#	Description 27.25" x 20.25" x 11" H at the rear	Cap.
14332	32MM Quick Change Collet Angled Platform	18
14342	42MM Quick Change Collet Angled Platform	18
14352	52MM Quick Change Collet Angled Platform	18
14365	65MM Quick Change Collet Angled Platform	15
14380	80MM Quick Change Collet Angled Platform	13
14399	100MM Quick Change Collet Angled Platform	10
EDP#	Tree Shelf Description	Cap.
55232	32MM Quick Change Collet Tree Shelf	17
55242	42MM Quick Change Collet Tree Shelf	17
55252	52MM Quick Change Collet Tree Shelf	17
55265	65MM Quick Change Collet Tree Shelf	12
55280	80MM Quick Change Collet Tree Shelf	8
55299	100MM Quick Change Collet Tree Shelf	6

EDP#	TriScoot Description 41" x 24.25" x 18"	Cap.
77332	32MM Quick Change Collet TriScoot	54
77342	42MM Quick Change Collet TriScoot	54
77352	52MM Quick Change Collet TriScoot	54
77365	65MM Quick Change Collet TriScoot	45
77380	80MM Quick Change Collet TriScoot	39
77399	100MM Quick Change Collet TriScoot	30

Huot Tree Shelves can be ordered for ToolScoot Trees and Lockers as shown on pages 9, 10 and 13.



Tall Locker with Quick Change Collets



Tall Locker with ER/Swiss Collets



Wall Locker with Quick Change Collets



ToolScoot Tree with Quick Change Collets



ToolScoot Tree with ER collets



ToolScoot Tree with Swiss Collets



Standard Collet Racks for ER/RD/DR/DA/TG



- Made of 14 gauge steel finished in epoxy, powder paint
- Physically small racks with good capacity
- For almost any size of collets
- For table tops, drawers, Scoot side trays or Huot Tree Utility shelves

EDP#	Description	Hole Size	Capacity
14800	7.21875" W x 9.125" D x 1.375" H Holds 11 Series Collets ER/RD/DR.	27/64"	49
14801	Holds 16 Series ER/RD/DR	39/64"	49
14802	Holds 20 Series ER/RD/DR	49/64"	36
14810	Holds DA300 Collets	5/16"	49
14811	Holds DA200 Collets	15/32"	49
14813	Holds DA100 Collets	43/64"	36
EDP#	Description	Hole Size	Capacity
14803	17" W x 9-1/8" D x 2" H Holds 25 Series Collets ER/RD/DR	61/64"	48
14804	Holds 32 Series Collets ER/RD/DR	1-13/64"	40
14805	Holds 40 Series ER/RD/DR	1-1/2"	27
14806	Holds 50 Series Collets ER/RD/DR	2"	21
14812	Holds DA180 Collets	29/32"	48
14820	Holds TG75 Collets	1-1/32"	40
14821	Holds TG100 Collets	1-5/16"	27
14822	Holds TG150 Collets	1-59/64"	21

Large Collet Racks for ER/RD/DR/DA/TG

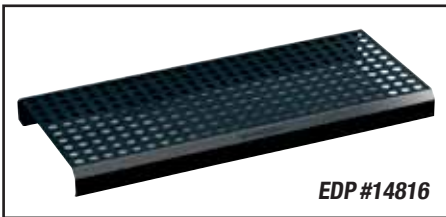

- Made of 14 gauge steel finished in epoxy powder paint
- Large capacity for the same series of collets
- Designed to fit in Tree Utility shelves

EDP#	Description	Hole Size	Capacity
14816	26-17/32" W x 11-17/32" D x 2" H ER16, 1" x 1" spacing	39/64"	260
14817	ER20, 1-3/16" x 1-1/4" spacing	49/64"	176
14818	ER25, 1-3/8" x 1-5/8" spacing	61/64"	114
14819	ER32, 1-21/32" x 1-3/4" spacing	1-13/64"	90
14827	TG100, 1-7/8" x 2" spacing	1-5/16"	70

Swiss Collet Racks

- For collets, guides, bushings and sleeves typically used in Swiss applications
- Based on our ER collet rack designs
- For every machine type or brand
- Racks use 10 different fixed hold sizes
- Large capacity depending on diameter
- Tall enough at 4" to hold most collets or bushings
- Designed to fit in the Huot Tree Utility Shelf
- Made of 14 gauge steel finished in epoxy powder paint

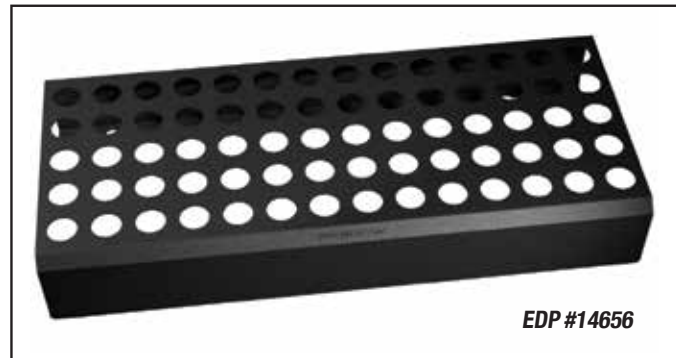

EDP#	Description	Capacity
14650	26.5" W x 11" D x 4" H 12 lbs .604" Hole Size	260
14651	.770" Hole Size	176
14652	.854" Hole Size	133
14653	.948" Hole Size	114
14654	1.075" Hole Size	102

EDP#	Description	Capacity
14655	26.5" W x 11" D x 4" H 12 lbs 1.195" Hole Size	90
14656	1.307" Hole Size	70
14657	1.495" Hole Size	48
14658	1.745" Hole Size	44
14659	1.995" Hole Size	34

Machine Mount Rack



EDP #56740

- Small rack mounts directly to machine, wall, anywhere tools are needed
- Miniature version of our Wall Tree
- Excellent capacity for a small rack
- Shelves mount flat or at a -20° angle
- Base has 6 mounting positions
- Shelf heights are adjustable with 14 positions per side
- Beveled corners for safety
- Low profile - only protrudes 11" from surface
- Ideal for special ops tools



Scan for
YouTube video



EDP #56777

- Inexpensive, handy option
- Easily mounts in chassis slots next to shelf tabs
- Ideal for collet racks or as a laptop/writing surface

EDP#	Description	Capacity
	18.25" H x 19" W x 11" D, 19 lbs	
56740	BT, CAT, NMTB 40 taper	28
56744	CAPTO® C4 taper	28
56745	CAPTO® C5 taper	28
56746	CAPTO® C6 taper	28
56750	BT, CAT, NMTB 50 taper	16
56764	HSK 40A, 40C, 40E and KM40 tapers	28
56770	HSK 63A taper	28
56780	HSK 100A taper	16
EDP#	Accessories	
56777	Accessory Tray 17.375" W X 10.625" D X 10.5" H, 8 lbs	

Horizontal Toolholder Rack



EDP #14776

- Mounts on machine, wall, bench, wherever toolholders are needed
- Horizontal orientation
- Available for most popular tapers
- Uses molded inserts to hold and protect tools
- Ideal for special ops or preset tools

EDP#	Description	Capacity
	24" W x 5" L x 4.875" H, 7 lbs	
14763	KM 63 taper	7
14764	HSK 40A, 40C, 40E and KM40 tapers	7
14771	BT, CAT, NMTB 40 taper	7
14776	BT, CAT, NMTB 50 taper	5
14777	BT, CAT, NMTB 30 taper	7
14781	HSK 63A taper	7
14791	HSK 100A taper	5
14784	CAPTO® C4 taper	7
14785	CAPTO® C5 taper	7
14786	CAPTO® C6 taper	7

Vertical Toolholder Rack

- Mounts on machine, wall, bench, wherever toolholders are needed
- Vertical orientation
- Angled lower positions, flat top position
- Available for most popular tapers
- Uses molded inserts to hold and protect tools
- Ideal for special ops or preset tools

EDP#	Description	Capacity
	29.8" H x 7" W x 3.125" D, 9 lbs	
14740	Vertical Rack for BT, CAT, NMTB 40 taper	6
14741	Vertical Rack for HSK 40A taper	6
14742	Vertical Rack for HSK 63A taper	6
14743	Vertical Rack for BT, CAT, NMTB 30 taper	6
14744	Vertical Rack for CAPTO® C4 taper	6
14745	Vertical Rack for CAPTO® C5 taper	6
14746	Vertical Rack for CAPTO® C6 taper	6
14777	Vertical Rack for VDI 30 taper	6
14778	Vertical Rack for VDI 40 taper	6



EDP #14740

CAPTO® is a registered trademark of Sandvik AB

Machine Tool Accessory Rack

EDP #14702

- Organizes tools for daily operation of any machine
- Mounts to machine, wall, workbench, anywhere
- Made of 16 gauge cold rolled steel
- Pre-punched to hold Bondhus 13 pc fractional and 9 pc metric hex wrench sets
- Also pre-punched to hold Huot Bit Buddy fractional drill indexes on either side
- Compatible with 5S initiatives
- Dimensions: 17½" L x 5¾" D x 2¾" H



Angled Platforms



- Table top design provides easy access to tools
- Angled design for easier selection of tools
- Many tapers and collet types available

EDP#	Description	Capacity
14332	32MM Quick Change Collet Angled Platform	18
14342	42MM Quick Change Collet Angled Platform	18
14352	52MM Quick Change Collet Angled Platform	18
14365	65MM Quick Change Collet Angled Platform	15
14380	80MM Quick Change Collet Angled Platform	13
14399	100MM Quick Change Collet Angled Platform	10

EDP#	Description	Capacity
	27.25" W x 20.25" D x 11" H at rear of rack, 15 lbs	
14858	20C collets	24
14863	KM 63 taper	24
14880	HSK 63A taper	24
14885	HSK 100A taper	18
14830	BT, CAT, NMTB 30 taper	24
14840	BT, CAT, NMTB 40 taper	24
14844	HSK 40A, 40C, 40E and KM40 tapers	24
14850	BT, CAT, NMTB 50 taper	18
14856	5C collets	48
14857	16C collets	50
14866	R8 collets or #4 Morse Taper	50
14822	HSK 63F taper	24
EDP#	Description	Capacity
14823	CAPTO® C3 taper	24
14824	CAPTO® C4 taper	24
14825	CAPTO® C5 taper	24
14826	CAPTO® C6 taper	24
14828	CAPTO® C8 taper	18
14833	VDI 30 taper	24
14834	VDI 40 taper	24

CAPTO® is a registered trademark of Sandvik AB

Toolholder/Collet Rack



EDP #14728

- Holds NC Toolholders, Collets & Tap Adapters
- Angled for easier selection of stored tools
- Mounts on bench top or fits neatly inside standard 36" industrial cabinet
- Heavy gauge steel with epoxy powder finish

EDP#	Description 12.5" W x 16.5" D x 6.75" H	Weight
14725	40 Taper NC rack has 12 spaces for toolholders, 7 spaces for Tap Drivers or DA-180 Series Collets, 8 spaces for DA-180 Series, 10 spaces for DA-200 Series, 9 spaces for DA-300 Series.	5.5 lbs
14728	40 Taper NC Tool Holder has 12 spaces for each of the following: 40 taper toolholders, ER16 Collets and ER32 Collets.	5.5 lbs
14730	30 Taper NC Tool Holder has 12 spaces for toolholders, 7 spaces for Tap Drivers or DA-180 Series Collets, 8 spaces for DA-180 Series, 10 spaces for DA-200 Series, 9 spaces for DA-300 Series.	5.5 lbs

Toolholder Tote Rack



EDP #14790

EDP#	Description 28.75" L x 5.25" W x 6" H, 6 lbs	Capacity
14765	BT, CAT, NMTB 30 taper	6
14780	BT, CAT, NMTB 40 taper	6
14749	HSK 40A, 40C, 40E and KM40 tapers	6
14790	BT, CAT, NMTB 50 taper	5
14770	HSK 63A taper	6
14775	HSK 100A taper	5

- Heavy gauge steel with molded inserts to help protect your tooling
- Painted texture black with pollution free powder coating process
- Built-in handles for comfortable carrying

5C, R8 Collet Racks

- Angled for visibility and easier selection of stored collets
- Tough, solvent free, epoxy finish
- Ecolo-Clad for long lasting protection

EDP #14600 Holds up to 30 pieces 5C Collets
Dimensions: Top 9" W x 12" D Weight: 3 lbs

EDP #14625 Holds up to 17 R8 Collets
Dimensions: Top 5¼" W x 9" D Weight: 2 lbs

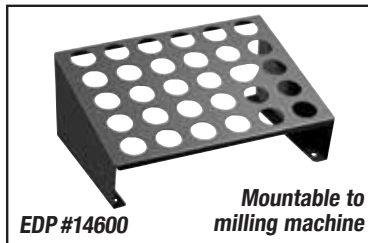

EDP #14600

Mountable to milling machine



EDP #14625

Drop-In Drawer Inserts

EDP#	Description 23.5" x 23.5"	Height	Cap.
22030	BT, CAT, NMTB 30 taper	4"	42
22040	BT, CAT, NMTB 40 taper	4"	42
22050	BT, CAT, NMTB 50 taper	6"	23
22064	HSK 40A, 40C, 40E and KM40	4"	42
22070	HSK 63A taper	4"	42
22072	Divided tray	4"	N/A
22080	HSK 100A taper	6"	23
22800	TG 100 collets	4"	144
22816	ER 16 collets	4"	361
22820	ER 20 collets	4"	289
22825	ER 25 collets	4"	196
22832	ER 32 collets	4"	144

Also available for CAPTO®

- These 23½" x 23½" drop-in inserts are designed to fit in 24" x 24" cabinet drawers
- Sturdy steel construction ensures proper support and fit of your tools
- This simple product allows for organization using the existing furnishings in your facility



EDP #22040

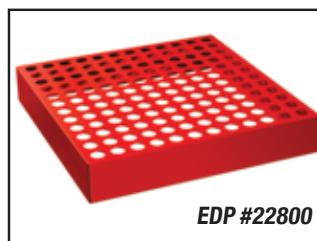

EDP #22800



EDP #22072

Original Dispenser Series

Original Dispenser Series Features

- Original series are as the name implies, the first style of dispensers that Huot created
- Models have 3, 4 or 5 drawers and weigh between 10 and 14 lbs without tools
- Designed to hold a full package of each size in jobber length
- Decimal equivalents shown on drawer labels



EDP #13000

- Indents and protrusions on the top and bottom of the dispenser allow for easy stacking
- One piece compound slides provide long life
- Rounded column bottoms for easy tool removal
- All models measure 14 5/8" W x 7 5/8" D x 7 3/4" H

Drills Frac/Wire/Letter/Metric

EDP #13000

- Holds Fractional Drills 1/16" to 1/2" by 64ths

Weight: 10 lbs

EDP #13025

- Holds Wire Gauge Drills #1 to #60

Weight: 13 lbs

EDP #13050

- Holds A to Z Letter Size Drills

Weight: 10 lbs

EDP #13075

- Holds Metric Drills 1MM to 13MM by 0.5MM

Weight: 13 lbs

EDP #13100

- Holds Metric Drills 1MM to 6.9MM by 0.1MM

Weight: 13 lbs

EDP #13040

- Holds Wire Gauge Drills #1 to #80

Weight: 13.75 lbs

Stub/Screw Machine

EDP #13015

- Holds Stub drills 1/6" to 1/2" x 64ths

Weight: 10.25 lbs each

EDP #13030

- Holds Stub drills 1-60

Weight: 13.25 lbs. each

EDP #13060

- Holds Stub drills A-Z

Weight: 10.25 lbs each

EDP #13080

- Holds Stub drills 1mm-13mm x 0.5mm

Weight: 10.25 lbs each

EDP #13090

- Holds Stub drills 1mm-6.9mm x 0.1mm

Weight: 13.75 lbs each

Taps



EDP #13500

EDP #13500

Holds NC and NF taps:

- 1/4"-20NC 1/4"-28NF 5/16"-18NC 5/16"-24NF 3/8"-16NC 3/8"-24NF
- 7/16"-14NC 7/16"-20NF 1/2"-13NC 1/2"-20NF 9/16"-12NC 9/16"-18NF
- 5/8"-11NC 5/8"-18NF 3/4"-10NC 3/4"-16NF 7/8"-9NC 7/8"-14NF
- 1"-8NC 1"-12NF

Weight: 10.5 lbs

EDP #13550

Holds taper, plug, bottoming and machine screw sizes:

- 2-56 3-48 3-56 4-40 4-48 5-40 5-44 6-32
- 6-40 8-32 8-36 10-24 10-32 12-24 12-28

Weight: 13 lbs

EDP #13575

Holds 29 popular metric sizes:

- 3mm x .50 3mm x .60 4mm x .70 4mm x .75
- 5mm x .80 5mm x .90 6mm x 1.00 6.3mm x 1.00
- 7mm x 1.00 8mm x 1.00 8mm x 1.25 9mm x .75
- 9mm x 1.00 9mm x 1.25 10mm x 1.00 10mm x 1.25
- 10mm x 1.50 11mm x 1.50 12mm x 1.25 12mm x 1.50
- 12 mm x 1.75 14mm x 1.25 14mm x 1.50 14mm x 2.00
- 16mm x 1.50 16mm x 2.00 18 mm x 2.50 20mm x 2.50
- 24mm x 3.00

Weight: 10.5 lbs

Silver Deming

EDP #13166

- Holds 2 each reduced shank S/D bits from 33/64ths to 63/64ths by 64ths

Weight: 13.25 lbs

EDP #13167

- Holds 2 each reduced shank S/D bits 1", 1-1/32, 1-1/16, 1-1/8, 1-5/32, 1-3/16, 1-1/4, 1-5/16, 1-3/8, 1-7/16, 1-1/2

Weight: 10.75 lbs

National Pipe Taps



EDP #13560

EDP #13560

Holds all sizes of National Pipe Taps (NPT) from 1/16" to 2"

- Top drawer #1 holds 1/16"-27 to 1/2"-14 in 13 compartments
- Drawer #2 holds 3/4"-14 to 1-1/4"-11-1/2" in 6 compartments
- Drawer #3 holds 1-1/2"-11-1/2" to 2"-11-1/2" in 2 compartments

Weight: 10.25 lbs

See huot.com for more details

Metric Taps, Drills & Dies



EDP #13595

EDP #13595

Holds Metric taps, drill and dies

- Top drawer #1 holds:
 - 2.5 x .45 tap - 2.05 drill, dies
 - 3.0 x .50 tap - 2.50 drill, dies
 - 3.5 x .60 tap - 2.90 drill, dies
 - 4.0 x .70 tap - 3.30 drill, dies
- Drawer #2 holds:
 - 5.0 x .80 tap - 4.20 drill, dies
 - 6.0 x 1.0 tap - 5.00 drill, dies
 - 8.0 x 1.25 tap - 6.70 drill, dies
- Drawer #3 holds:
 - 10.0 x 1.50 tap - 8.50 drill, dies
 - 12.0 x 1.75 tap - 10.20 drill, dies

Weight: 10.25 lbs

See huot.com for more details

Taps and Drills



EDP #13590

EDP #13590

Stores and organizes correct drill with corresponding size tap

TAP	DRILL	TAP	DRILL
6 - 32	#36	5/16 - 24	I
8 - 32	#29	3/8 - 16	5/16
10 - 24	#25	3/8 - 24	Q
10 - 32	#21	7/16 - 14	U
1/4 - 20	#7	7/16 - 20	25/64
1/4 - 28	#3	1/2 - 13	27/64
5/16 - 18	F	1/2 - 20	29/64

Weight: 10.5 lbs

See huot.com for more details

Counterbores



EDP #13570

EDP #13570

Holds continuous pilot counterbore sizes:

- #4, #5, #6, #8, #10, #12, 1/4", 5/16", 3/8" 7/16" & 1/2"

Weight: 14 lbs

Step Drills

EDP #13652

- Pre-labeled from 1/8" to 1-3/8" sizes
- Multiple bits per compartment storage
- Also stores corresponding center drills
- Also comes with custom labeling kit
- Can be labeled to your needs
- Weight: 10.25 lbs



EDP 13652

End Mills



EDP #13350

EDP #13350

For small end mill inventories:

- Top drawer #1 holds 9/16", 11/16" 7/8"
- Drawer #2 holds 3/16", 5/16" 7/16" 5/8" 1"
- Drawer #3 holds 1/8", 1/4", 3/8", 1/2", 3/4"

Weight: 10.25 lbs

Reamers



EDP #13410

EDP #13410

- Holds Fractional Reamers 1/16" to 1/2" by 64th's
- Weight: 13 lbs

EDP #13415

- Holds A to Z Letter Size Reamers
- Weight: 13 lbs

EDP #13420

- Holds Wire Gauge Drills #1 to #60
- Weight: 13 lbs

EDP #13425

- Holds Metric Reamers 1MM to 13MM by 0.5MM
- Weight: 14 lbs

EDP #13430

- Holds Over/Under and Dowel Pin Sizes
- Weight: 11 lbs

Carbide Burrs



EDP #13200

EDP #13200

Holds the following sizes:

- Top drawer #1 holds Cylindrical 1/4" x 5/8", Cyl. Rad. End. 1/4" x 5/8", Ball 1/4" x 1/4", Oval 1/4" x 3/8", Tree Rad. 1/4" x 3/4", Tree/Pointed 1/4" x 3/4", Cone/Rad. End 1/4" x 5/8", Cylindrical 3/8" x 3/4", Cyl./Rad. End 3/8" x 3/4", Ball 3/8", Oval 3/8" x 5/8", Tree/Rad. End 3/8" x 3/4"
- Drawer #2 holds Tree Pointed 3/8" x 3/4", Cone Rad./End 3/8" x 1-1/16", Cone Flat/End 1/4" x 1", Cone Rad./End 1/2" x 1-1/8", Cone Flat/End 3/8 x 1", Cylindrical 1/2" x 1"
- Drawer #3 holds Cyl. Rad. End. 1/2" x 1", Ball 1/2", Oval 1/2" x 7/8", Tree/Rad. End 1/2" x 1", Tree Pointed 1/2" x 1", Cone Flat/End 1/2 x 1"

Weight: 10.5 lbs

Carbide Inserts



EDP #13650

EDP #13650

- Designed to keep inserts at each work center
 - Compact size and affordable price lets the user keep the most frequently used inserts within fingertip reach
 - Three drawers have a moveable divider with a large fourth drawer to store tool holders and extra inserts
 - Label holders on drawer fronts permit easy, quick identification and inventory check
 - Stackable with other cutting tool storage cabinets to save space
- Weight: 13 lbs

Master Dispenser Series Features

Master Dispenser Series Features

- Same function as the Original Dispensers with more features
- Master Dispensers consolidate several Original Dispensers in one cabinet
- Models have 3, 4, 5 or 6 drawers and weigh between 40 and 80 lbs without tools in them
- Designed to hold a full package of each size in jobber length, with room for spares
- Drawer divider kits available for lower drawer



EDP #13175

- Decimal equivalents shown on drawer labels
- Included clips slide into cabinet tops to facilitate stacking
- Full extension ball bearing slide for smooth operation and long life
- Rounded column bottoms for easy tool removal
- All drawers have detent locks and cabinet has key lock
- Dimensions: 26" W x 12" D x 12½" H, unless otherwise specified

Drills Frac/Wire/Letter/Metric

EDP #13175

Holds full packages (minimum 12 pcs) of jobber or screw machine length drills in fractional, wire gauge and letter sizes.

- Top drawer holds fractional drills 1/16" to 1/2" by 64th's in 42 compartments
- 2nd drawer is for #1 to #60 wire gauge in 75 compartments
- 3rd drawer for letter size A to Z in 42 compartments

Weight: 50 lbs

Scan QR code for detail including drawer configuration photos.



Open drawer from 13175

EDP #13085

Holds Metric drills

- 1MM to 25MM x 0.5MM

Weight: 50 lbs

Scan QR code for detail including drawer configuration photos.



Silver Deming

EDP #13165

Holds the following Silver Deming drills.

- Top drawer #1 holds 33/64" to 37/64" in 25 compartments
- Drawer #2 holds 19/32" to 21/32" in 25 compartments
- Drawer #3 holds 43/64" to 47/64" in 25 compartments
- Drawer #4 hold 3/4" to 27/32" in 17 compartments
- Drawer #5 holds 55/64" to 31/32" in 17 compartments
- Drawer #6 holds 63/64" to 1 1/2" in 17 compartments

Dimensions: 26" W x 12" D x 15 -7/8" H

Weight: 80 lbs

Scan QR code for detail including drawer configuration photos.



EDP #13180

Holds metric drills from 0.35MM to 13.0MM

- Top drawer #1 holds 0.35MM to 5.6MM
- Drawer #2 holds 5.7MM to 9.3MM
- Drawer #3 holds 9.3MM to 13.0MM
- Drawer #4 is open for spares and longer drills

Weight: 50 lbs

Scan QR code for detail including drawer configuration photos.



Taper Shank & Length

EDP #13185

Stores taper length or taper shank drills

- 1/8" to 1" by 64ths

Weight: 50 lbs

Scan QR code for detail including drawer configuration photos.



EDP #13190

Holds full packages (minimum 12 pcs) of jobber or screw machine length drills in fractional, wire gauge, letter sizes and metric drills.

- Top drawer #1 holds fractional drills 1/16" to 1/2" by 64th's in 42 compartments
- Drawer #2 holds wire gauge #1 to #60 in 75 compartments
- Drawer #3 letter sizes A to Z in 42 compartments
- Drawer #4 hold metric sizes 0.35MM to 5.6MM in 75 compartments
- Drawer #5 holds metric drills sizes 5.7MM to 9.3MM in 59 compartments
- Drawer #6 holds metric drill sizes 9.4MM to 13.0MM in 21 compartments

Dimensions: 26" W x 12" D x 15 -7/8" H

Weight: 80 lbs

Scan QR code for detail including drawer configuration photos.



Taps

EDP #13585

Holds common NC and NF, metric and machine screw sizes

- Top drawer #1 holds machine screw size 2-56 to 12-28 taper plug, bottom and spiral in 40 compartments
- Drawer #2 holds metric sizes from 2.5MM to 30MM in 78 compartments
- Drawer #3 holds 1/4"-20 NC to 7/8"-14 NF in 21 compartments
- Drawer #4 holds 1"-8 NC to 1-1/2"-12 NF in 13 compartments

Weight: 50 lbs

Scan QR code for detail including drawer configuration photos.



EDP #13580

For sizes 1/4"-20 to 1"-14 taps

- Holds bottom, plug and taper of each size:

1/4"-20 1/4"-28 5/16"-18 5/16"-24 3/8"-16 3/8"-24 7/16"-14 7/16"-20
 1/2"-13 1/2"-20 9/16"-12 9/16"-18 5/8"-11 5/8"-18 3/4"-10 3/4"-16
 7/8"-9 7/8"-14 1"-8 1"-14

- Holds taper, plug, bottom and spiral:

2-56 3-48 3-56 4-40 4-48
 5-40 5-44 6-32 6-40 8-32
 8-36 10-24 10-32 12-24 12-28

Weight: 50 lbs

Scan QR code for detail including drawer configuration photos.



Tap & Drill



EDP #13597

EDP #13597

Holds tap and drill sizes #0 to #80 3/64 1.5-12 1-27/64

- Holds tap with corresponding drill next it
- Hold a dozen of the smaller sizes and several of the larger sizes
- Tap/drill charts on drawer front

Weight: 50 lbs

Scan QR code for detail including drawer configuration photos.



EDP #13599

EDP #13599

Holds metric tap and drill sizes M1.6 x 0.35 tap with 1.25MM drill to M24 x 2.0 with 22MM drill

- Holds tap with corresponding drill next it
- Hold a dozen of the smaller sizes and several of the larger sizes

Weight: 50 lbs

Scan QR code for detail including drawer configuration photos.



Reamers

EDP #13400

- Stores the following reamers:

1/8"-4 ea., .1230 d/p, .1240 under, .1247 d/p, .1260 over, 3 ea. 3/16",
 .1855 d/p, .1865 under, .1870 d/p, .1885 over, 3 ea. 1/4"-4 ea.,
 .2480 d/p, .2490 under, .2495 d/p, .2510 over, 3 ea. 5/16"-3 ea.,
 .3105 d/p-3 ea., .3115 under 2 ea., .3120 d/p-2ea., .3135 over-2 ea.
 3/8"-4 ea., .3730 d/p, .3740 under, .3745 d/p, .3760 over, 3 ea. 7/16",
 .4355 d/p, .4365 under, .4370 d/p, .4385 over, 2 ea. 1/2"-4 ea.,
 .4980 d/p-2 ea., .4990 under, .4995 d/p,
 .5010 over, 3 ea.

Dimensions: 26" W x 12" D x 9 5/16" H

Weight: 40 lbs

Scan QR code for detail including drawer configuration photos.



EDP #13450

Holds the following reamer sizes:

- Top drawer #1 holds metric reamers 1MM to 13MM x 0.5MM
- Drawer #2 holds Fractional reamers 1/16" to 1/2"
- Drawer #3 holds Over/Under reamers from .1240 to .5010
- Drawer #4 holds Dowel Pin reamers from .1230 to .4995

Weight: 50 lbs

Scan QR code for detail including drawer configuration photos.



Under-Mount Drill Dispensers

EDP# 30000 for fractional drills 1/16" to 1/2" x 64ths

EDP# 30025 for wire gage drills #1 to #60

EDP# 30050 for A to Z letter drills

EDP# 30001 open drawer, no dividers

- The under-mount Drill Dispenser can be mounted under a bench, secured to a shelf, or mounted on the bottom of a Tree family Utility Shelf
- Ball bearing slides with detent locks ensure smooth operation
- Key lock helps keeps tools safe and secure

Overall Dimensions:

26 1/2" W x 12 1/2" D x 4 1/2" H

Drawer Dimensions:

23 3/4" W x 11" D x 3" H

Weight: 14.5 lbs

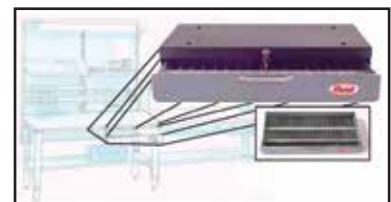

End Mills



EDP #13325

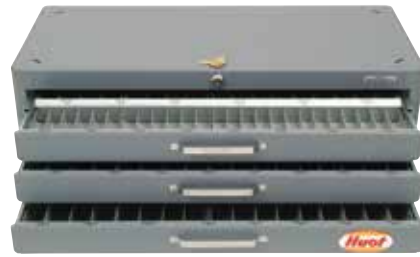

EDP #13375

EDP #13300

Holds 2 flute double end and single end mills

- Top drawer #1 holds single end fractional end mills 1/8" to 1" in 41 compartments with extra space for specials
- Drawer #2 holds double end fractional end mills 1/16" to 1", multiple shank sizes in 41 compartments
- Drawer #3 open for other tools or specials. Optional divider kit available

Dimensions: 26" W x 12" D x 9 -3/8" H

Weight: 40 lbs

Scan QR code for detail including drawer configuration photos.



EDP #13325

Holds 4 flute double end and single end mills

- Top drawer #1 holds single end fractional end mills 1/8" to 1" in 41 compartments with extra space for specials
- Drawer #2 holds double end fractional end mills 1/16" to 1", multiple shank sizes in 41 compartments
- Drawer #3 open for other tools or specials. Optional divider kit available

Dimensions: 26" W x 12" D x 9 -3/8" H

Weight: 40 lbs

Scan QR code for detail including drawer configuration photos.



EDP #13375

Holds Metric End Mills:

- Top drawers #1 and drawer #2 holds sizes 2MM to 25MM in 60 compartments

- Drawer #3 is open for spares

Dimensions 26" W x 12" D x 9-5/16" H

Weight 40 lbs

EDP #13700

Holds the following reamer sizes:

- Top drawer #1 holds metric reamers 1MM to 13MM x 0.5MM
- Drawer #2 holds Fractional reamers 1/16" to 1/2"
- Drawer #3 holds Over/Under reamers from .1240 to .5010
- Drawer #4 holds Dowel Pin reamers from .1230 to .4995

Weight: 50 lbs

Scan QR code for detail including drawer configuration photos.



Carbide Inserts



EDP #13600

EDP #13600

- Holds Square, Triangular, Diamond and Round Inserts, with additional space for Specials
- 36 Compartments to hold packages or loose inserts. Measures 3 3/4" W x 5 1/2" D

- Pre-labeled for insert shape.

- Label set included for your personalized marking of size, radius, grind and thickness

- Lockable and comes with set of two keys

- Stackable with other dispensers

- Ball bearing drawer slides

Weight: 50 lbs

Scan QR code for detail including drawer configuration photos.



Universal Master Dispenser



EDP #13174

- Full extension ball bearing slides with posi-lock catch
- 72 movable dividers included
- 3 drawers are divided, bottom drawer is open for larger tools
- Columns are fixed at 3.25" wide
- Dividers are in 1" increments
- Drawers measure 10.5" front to back
- Key lock on all Master models
- Steel construction

Dimensions: 26" W x 12" D x 12½" H

Weight: 50 lbs

Dispenser Drawer Divider Kit

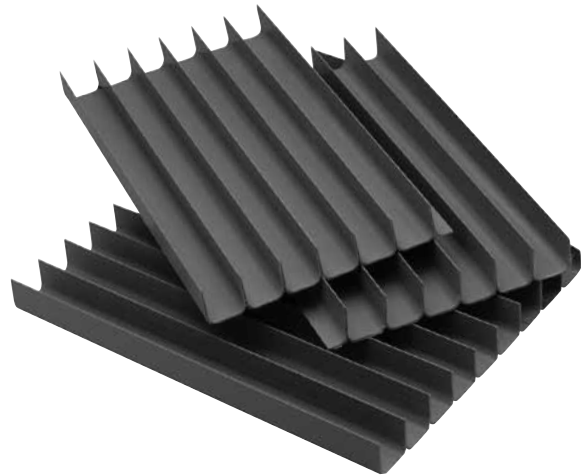

EDP #14030

- Four sections create 25 compartments in Huot Master Series standard 11" x 23-1/8" dispenser drawers and most tool boxes
- Individual compartments are each 11" deep x 15/16" wide x 1" high

EDP #14060

- Four sections create 17 compartments 1¼" wide and 11" deep
- Vinyl compartments separate tools to prevent damage and organize inventory
- Can be labeled for inventory control and tracking
- Use in combination with Protective Vinyl Webbing to multiply drawer capacity

Measuring Tool Master Dispenser



EDP #13321

Chances are you're storing your measuring tools in your tool box along with everything else. Ever wonder why your measuring tools are so beat up? Put those expensive and valuable tools in their own dedicated cabinet.

- For vernier calipers, micrometers, etc.
- Stackable with other Huot Masters
- Comes with stacking clips
- Oil and grease resistant drawer liners
- Foam liners provide a soft storage surface
- Durable gray powder coat finish
- Three drawers provide ample storage
- Ball bearing drawer slides
- Locking for security
- Dimensions: 26" W x 12" D x 12½" H

Master Dispenser Stands



EDP #13333

Master Dispenser Stands are more ergonomic. Instead of taking up valuable space on that bench top, this stand allows you to put your cutting tools next to the bench, not on it.

- Our Master Dispensers fit easily and securely in the top
- Cold rolled steel construction
- Ergonomic position reduces bending
- Black texture powder coat finish
- A safe and efficient addition to any shop
- Available in 12" or 26" heights
- Adjustable feet allow for leveling
- Assembles in minutes

Super Chest and Super Cabinet

- Solid welded drawer dividers front to back provide a rigid smooth surface with no holes to lose parts
- 24,000 combined cubic inches of usable storage space
- Heavy duty cam lock and hidden locking mechanism
- Rugged, exclusive I-beam doublewall construction
- 18 gauge, all steel construction with Huot's Ecolo-Clad plastic paint. Environmentally safe finish
- Steel skid keeps unit off floor and allows for stacking for even greater space savings
- Stackable. Two high maximum
- Label holders provide identification at a glance
- Each drawer rigidly constructed of solid steel with no holes in drawer bottom to keep small parts inside of drawer. Will hold 150 lbs. supported on full extension ball bearings slides
- Deeper drawers available

EDP #13530

Super chest with 8 drawer capacity.
240 individual drawer dividers included.
Dimensions: 34" W x 19 1/8" D x 23 1/8" H
Weight: 220 lbs

EDP #13525

Super cabinet with 15 drawer capacity.
480 individual drawer dividers included.
Dimensions: 34" W x 19 1/8" D x 38" H
Each drawer measures 29" W x 18" D x 2" H
Weight: 375 lbs



Scan for
YouTube video



EDP #13527



EDP #13530
Super Chest
stacked on
EDP #13525
Super Cabinet



No holes in
drawer bottom

3/4"
wide

Front to back
dividers
welded into position



Metal Drawer
Divider Kit
#8755

EDP #13527

Super cabinet with 8 drawer capacity.
7 drawers 4" high, 1 drawer 2" high.
480 individual drawer dividers provided.
Dimensions: 34" W x 19 1/8" D x 38" H.
Each drawer measures 29" W x 18" D x 2" H
Weight: 375 lbs

Huot Mfg. Co. does not manufacture or distribute cutting tools of any type. Cutting tools shown in all photos are for display purposes only.

Drill Indexes/U.S.

EDP #12750

For jobbers length fractional drills $\frac{1}{16}$ " to $\frac{1}{4}$ " inclusive by 64ths.

Dimensions: 4" W x $5\frac{3}{8}$ " D x $\frac{5}{16}$ " H

EDP #10350

For jobbers length fractional drills $\frac{1}{16}$ " to $\frac{1}{2}$ " inclusive by 32nds.

Dimensions: 4" W x 7" D x $1\frac{1}{4}$ " H

EDP #10400

For wire gauge drills No. 61 to 80.

Dimensions: $1\frac{1}{2}$ " W x 2" D x $\frac{3}{32}$ " H

EDP #10450 (21)

For jobbers length fractional drills $\frac{1}{16}$ " to $\frac{3}{8}$ " inclusive by 64ths.

Dimensions: 4" W x 6" D x $1\frac{1}{8}$ " H

EDP #10500 (26)

For letter size drills A to Z inclusive.

Dimensions: 4" W x 7" D x $1\frac{3}{4}$ " H

EDP #10550 (29)

For jobbers length fractional drills $\frac{1}{16}$ " to $\frac{1}{2}$ " by 64ths inclusive. Decimal equivalents and U.S.S. tap information included.

Dimensions: 4" W x 7" D x $1\frac{1}{4}$ " H



EDP #12750

EDP #10600

For wire gauge drills #1 to #60 inclusive. Decimal equivalents and machine screw tap information included.

Dimensions: $3\frac{1}{4}$ " W x $4\frac{1}{2}$ " D x 1" H

EDP #10800

For jobbers length fractional drills $\frac{1}{64}$ " to $\frac{1}{4}$ " by 64ths.

Dimensions: 4" W x $5\frac{3}{8}$ " D x $\frac{5}{16}$ " H

EDP #12300

For $\frac{1}{16}$ " to $\frac{1}{4}$ " by 64ths and $\frac{3}{32}$ " to $\frac{1}{2}$ " by 32nds, jobbers length.

Dimensions: 4" W x 7" D x $1\frac{1}{4}$ " H

EDP #10875

Maintenance Index

19 piece index holds every drill needed for frequent maintenance work in one handy index case. Holds $\frac{1}{16}$ ", $\frac{5}{64}$ ", $\frac{3}{32}$ ", $\frac{1}{8}$ ", #29, #25, $\frac{5}{32}$ ", #21, $\frac{3}{16}$ ", #7, $\frac{7}{32}$ ", $\frac{1}{4}$ ", #F, $\frac{5}{16}$ ", #U, $\frac{3}{8}$ ", $\frac{27}{64}$ ", $\frac{7}{16}$ ", $\frac{1}{2}$ ".

Dimensions: 4" W x 7" D x $1\frac{1}{4}$ " H

EDP #11655

Holds 6" OAL aircraft extension bits from $\frac{1}{16}$ " to $\frac{1}{2}$ " by 64ths.

Dimensions: 4" W x 2" D x $8\frac{3}{4}$ " H

Weight: 1.5 pounds.

EDP #15235

Holds jobber length drills $\frac{1}{8}$ ", $\frac{3}{16}$ ", $\frac{1}{4}$ ", $\frac{5}{16}$ ", $\frac{3}{8}$ ", $\frac{7}{16}$ ", $\frac{1}{2}$ ".

Dimensions: 4" W x 7" D x $1\frac{1}{4}$ " H

For metric sizes see page 26

Screw Extractor & Drill Index

EDP #10200

Holds #1, #2, #3, #4, #5 screw extractor and corresponding size drill bit.

Dimensions: 4" W x $5\frac{1}{2}$ " D x $\frac{1}{2}$ " H



EDP #10200

Reamer Cases

These handy, all-steel reamer cases are designed to hold the reamer securely by the shank to help protect delicate cutting edges. Indexed for reamer size in decimal equivalents, with raised embossed lettering for permanent identification.

EDP #12100

Over and Under sizes .124 - .126 to .499-.501 by 16ths. Holds 14 reamers.
Dimensions: 4" W x 8-5/8" D x 13/16" H

EDP #12125

For dowel pin reamers .123 to .4995. Holds 14 reamers.

Dimensions: 4" W x 8-5/8" D x 13/16" H



EDP #12050

EDP #12000

A to Z reamers.

Dimensions: 4" W x 8-5/8" D x 1-13/16" H

EDP #12050

Chucking reamers $\frac{1}{16}$ " to $\frac{1}{2}$ " by 64ths.
Dimensions: 4" W x 8-5/8" D x 1-13/16" H

EDP #12200

No.1 to 60 inclusive.

Dimensions: 3-3/8" W x 6-3/4" D x 13/16" H

EDP #12130

For metric reamers 1.00mm to 13.00mm by 0.5mm. Holds 25 reamers in an all steel case with easy to read mylar identification labels to pick the right size quickly and easily.

Dimensions: 8 $\frac{3}{4}$ " W x 4" D x $1\frac{3}{4}$ " H

Bit Buddy

Bit Buddy is all plastic, break resistant and water resistant, durable and holds Jobbers length or Mechanics length drill bits.

EDP #30550

For Jobbers length drills $\frac{1}{16}$ " to $\frac{1}{2}$ " by 64ths.

EDP #30650

For Mechanics length drills $\frac{1}{16}$ " to $\frac{1}{2}$ " by 64ths.

Huot Mfg. Co. does not manufacture or distribute cutting tools of any type. Cutting tools shown in all photos are for display purposes only.

Custom colors available in 1,000 piece minimum.



Combination Indexes



EDP #11700

EDP #11700

Holds 115 drills-29 fractional, 26 letter and 60 wire gauge; $\frac{1}{16}$ " to $\frac{1}{2}$ " by 64ths, 1 to 60, A to Z letter size. (Stub version EDP #11550 available see page 27).

EDP #11750

Same features as Model #115 above but includes the #61-80 wire gauge sizes in one complete index. Holds 135 drills.

EDP #11800

Holds 134 drills-29 fractional, #80 wire gauge and 25 metric; $\frac{1}{16}$ " to $\frac{1}{2}$ " by 64ths #1 to #80 wire gauge, 1mm to 13mm by 0.5mm.

Dimensions: $13\frac{1}{2}$ " W x $4\frac{5}{8}$ " D x $2\frac{1}{4}$ " H

Weight: 4 lbs

Ideal for keeping all of the most commonly used drills handy. Holds up to 135 drills in one combination case. Indexed for size and decimal equivalents.

EDP #11825

Holds 118 most popular metric bits from 1.0mm to 13.0mm. See metric indexes below for full description.

Dimensions: $13\frac{5}{16}$ " L x $4\frac{1}{2}$ " W x $2\frac{3}{4}$ " H

Weight: 4 lbs

EDP #11550

Holds 115 stub screw machine length drills in one case. For stub drills $\frac{1}{16}$ " to $\frac{1}{2}$ " by 64ths, 1 to 60 wire gauge and A to Z letter size.

Dimensions: $13\frac{1}{2}$ " W x $4\frac{5}{8}$ " D x $2\frac{1}{4}$ " H

Drill Indexes/Metric

EDP #11825

Holds 118 most popular metric bits from 1.0mm to 13.0mm. Sizes include:

- 1.00mm to 2.50mm by .05mm
- 2.6mm to 10.0mm by .1mm
- 10.2mm 10.5mm 10.8mm
- 11.0mm 11.2mm 11.5mm
- 11.8mm 12.0mm 12.2mm
- 12.5mm 12.8mm 13.0mm

U.S. decimal equivalents are given for each size drill.

Dimensions: $13\frac{5}{16}$ " L x $4\frac{1}{2}$ " W x $2\frac{3}{4}$ " H

Weight: 4 lbs

EDP #11000

1mm to 6mm inclusive by 0.5mm

Dimensions: 4" W x $5\frac{1}{2}$ " D x $\frac{1}{2}$ " H

EDP #11050

1mm to 7mm inclusive by 0.5mm

Dimensions: 4" W x $5\frac{1}{2}$ " D x $\frac{1}{2}$ " H



EDP #11825

EDP #11100

1mm to 10mm by 0.5mm inclusive.

Dimensions: 4" W x 6" D x $1\frac{1}{8}$ " H

EDP #11150

1mm to 13mm by 0.5mm inclusive.

Dimensions: 4" W x 7" D x $1\frac{3}{4}$ " H

EDP #11200

6mm to 10mm by 0.1mm inclusive.

Dimensions: $4\frac{1}{2}$ " W x $7\frac{7}{8}$ " D x $2\frac{1}{2}$ " H

EDP #11250

1mm to 5.9mm by 0.1mm inclusive.

Dimensions: $3\frac{1}{4}$ " W x $4\frac{1}{2}$ " D x 1" H

Silver Deming

EDP #10760

For drills: 9/16" to 1" by 16ths. Holds eight S/D drills securely by the 1/2" shank.

Dimensions: 8 1/2" L x 6 1/4" W x 2" H

Weight: 2.5 lbs

(See page 38 for S/D stand)



EDP #10760

Three index cases to complete S/D drills from 1/2" to 1" by 64ths

EDP #10761

15 S/D drills 1/2" to 23/32" by 64ths

EDP #10762

10 S/D drills 47/64" to 7/8" by 64ths

EDP #10763

8 S/D drills 57/64" to 1" by 64ths

Dimensions: 8 1/2" L x 6 1/4" W x 2" H

Weight: 2.5 lbs

Taper Shank/Taper Length

EDP #10900

For Morse taper shank and taper length straight shank drills 33/64" to 3/4" by 64ths.

Dimensions: 5 1/2" W x 12 7/8" D x 3 3/8" H

EDP #10950

For Morse taper shank and taper length straight shank drills 49/64" to 1" by 64ths.

Dimensions: 6 3/8" W x 15 1/8" D x 3 1/16" H



EDP #10900

EDP #11525

A to Z letter size taper length.

Dimensions: 8 3/4" W x 4" D x 1 3/4" H

EDP #11600

1/16" to 1/2" by 64ths taper length.

Dimensions: 8 3/4" W x 4" D x 1 3/4" H

EDP #11650

1 to 60 wire gauge taper length.

Dimensions: 6 3/4" W x 3 1/2" D x 1 1/4" H

Carbide Burr Indexes

Safely separates and holds carbide burrs of all types.

EDP #15030 Holds 8 pieces 1/4" shank.

EDP #15035 Holds 10 pieces 1/4" shank.

EDP #15040 Holds 8 pieces 1/8" shank.

Dimensions: 3 1/4" W x 4 1/2" D x 1" H



EDP #15035

Stub Screw Machine Indexes

EDP #11300

Index for stub screw machine length fractional drills 1/16" to 1/4" by 64ths.

Dimensions: 4" W x 5 3/8" D x 5/16" H

EDP #11350

Index for stub screw machine length fractional drills 1/16" to 3/8" by 64ths.

Dimensions: 4" W x 4 5/8" D x 5/8" H

EDP #11375

For metric stub drills 1 to 13 mm by 0.5 mm. Decimal equivalents and screw information included.

Dimensions: 4" W x 7" D x 1 1/4" H

EDP #11400

For stub screw machine letter drills A to Z.

Dimensions: 4" W x 7" D x 1 1/4" H

EDP #11450



EDP #11450

Index for stub screw machine length fractional drills, 1/16" to 1/2" by 64ths. Decimal equivalents and U.S.S. tap information included.

Dimensions: 4" W x 7" D x 1 1/4" H

EDP #11500

For stub screw machine length drills wire gauge #1 to #60 inclusive, decimal equivalents and screw tap information.

Dimensions: 3 1/4" W x 4 1/2" D x 1" H

EDP #11550

Holds 115 stub screw machine length drills in one case. See the Combination Index section for additional details. For stub drills 1/16" to 1/2" by 64ths, 1 to 60 wire gauge and A to Z letter size.

Dimensions: 13 1/2" W x 4 5/8" D x 2 1/4" H

Tap Indexes

EDP #12575

Holds coarse and fine

1/4" - 20	1/4" - 28
5/16" - 18	5/16" - 24
3/8" - 16	3/8" - 24
7/16" - 14	7/16" - 20
1/2" - 13	1/2" - 20

EDP #12550

Holds fine and coarse

0 - 80	5 - 40	5 - 44	
1 - 72	1 - 64	6 - 32	6 - 40
2 - 56	2 - 64	8 - 32	8 - 36
3 - 48	3 - 56	10 - 24	10 - 32
4 - 40	4 - 48	12 - 24	12 - 28



EDP #12550



EDP #12590

EDP #12590

Holds the following 10 U.S. tap sizes:

4-40NC	1/4"-20NC
6-32NC	5/16"-18NC
8-32NC	3/8"-16NC
10-24NC	1/2"-13NC
10-32NF	5/8"-11NC

Or the following 10 metric tap sizes:

16 x 2.0	5 x .8
12 x 1.75	4.5 x .75
10 x 1.5	4 x .7
8 x 1.25	3.5 x .6
6 x 1.0	3 x .5

Dimensions: All models measure

3 1/4" W x 4 1/2" D x 1" H

Tap and Drill Indexes

EDP #12700

Conveniently combines taps with the corresponding tap drill alongside of one another.

- National Fine
- Holds sizes: 6-40 tap #33 drill, 8-36 #29, 10-32 #21, 12-28 #15, 1/4"-28 #3, 5/16"-24 #1, 3/8"-24 #Q, 7/16"-20 #25/64, 1/2"-20 #29/64.
- National Coarse
- Holds sizes: 6-32 tap #36 drill, 8-32 #29, 10-24 #25, 12-24 #16, 1/4"-20 #7, 5/16"-18 #F, 3/8"-16 #5/16", 7/16"-14 #U, 1/2"-13 #27/64.
- Clips mounted in the cover provide a handy place for securing your T-handle or adjustable tap wrench.

Dimensions: 13 1/2" W x 4 1/2" D x 2 3/4" H



EDP #12700

EDP #12600

- National Coarse
- Holds sizes: 6-32 tap #36 drill, 8-32 #29, 10-24 #25, 10-32 #21, 1/4"-20 #7, 5/16"-18 #F, 3/8"-16 #5/16", 7/16"-14 #U, 1/2"-13 #27/64

Dimensions: 4" W x 7" D x 1 1/4" H

EDP #12650

- National Fine
- Holds Sizes: 6-40 tap #33 drill, 8-36 #29, 10-24 #25, 10-32 #21, 1/4"-28 #3, 5/16"-24 #1, 3/8"-24 #Q, 7/16"-20 #25/64, 1/2"-20 #29/64.

Dimensions: 4" W x 7" D x 1 1/4" H

EDP #12675

- I.S.O. 529 1975
- Holds Sizes: 2.5 x 0.45 tap 2.05 drill, 3.0 x 0.50 2.50, 3.5 x 0.60 2.90, 4.0 x 0.70 3.30, 5.0 x 0.80 4.20, 6.0 x 1.00 5.00, 8.00 x 1.25 6.70, 10.0 x 1.50 8.50, 12.0 x 1.75 10.20

Dimensions: 4" W x 7" D x 1 1/4" H

Drill Stands, Jobber or Stub Screw

EDP #11850

Letter sizes A to Z inclusive

Dimensions: 5 5/8" W x 2 5/8" D x 1 1/2" H

Weight: 3 lbs



EDP #11900

EDP #11900

Fractional drills 1/8" to 1/2" by 64ths inclusive.

Dimensions: 5 5/8" W x 2 5/8" D x 1 1/2" H

Weight: 3 lbs

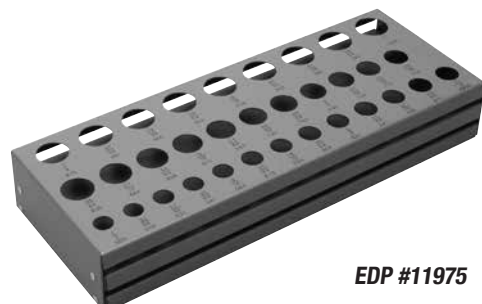

EDP #11975

EDP #11975

For jobbers and stub or screw machine

length from 1/2" to 1" by 64ths "held by flute"

Dimensions: 13" W x 5" D x 2" H

Weight: 3 lbs

Silver Deming

EDP #11985

For Silver Deming drills from 1/2" to 1" by 64ths held by shank.

Dimensions: 3" W x 5" D x 2" H

Weight: 3 lbs

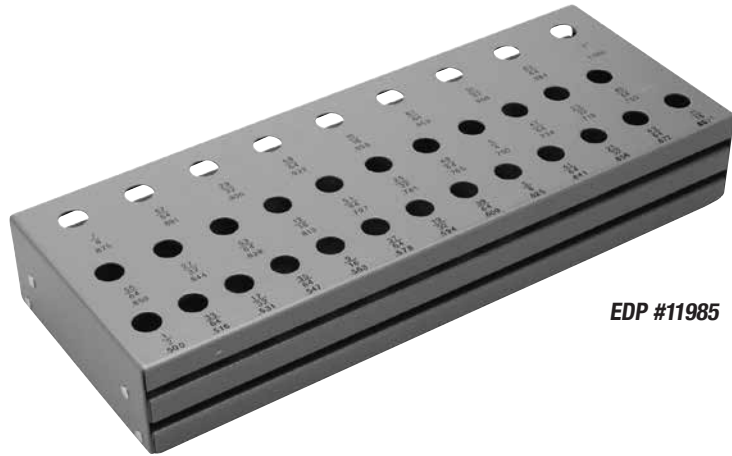

EDP #11985

Carbide Burr Stand

EDP #11875

Holds 24 each, 1/4" shank burrs. Holds up to 24, 1/4" shank burrs. Mounts on wall or drill press for easy accessibility.

Made from a single piece of steel.

Dimensions: 5-5/8" W x 2-5/8" D x 1 1/2" H



EDP #11875

Drill Gauges

EDP #12250

For measuring 1/16" to 1/2" by 64ths drill bits.

Dimensions: 6" W x 3" D

EDP #12260

For measuring #1 to 60 wire gauge drill bits.

Dimensions: 5 1/4" W x 2" D

EDP #12280

For measuring drills 1/2" to 1" by 64ths.

Dimensions: 13" W x 5" D

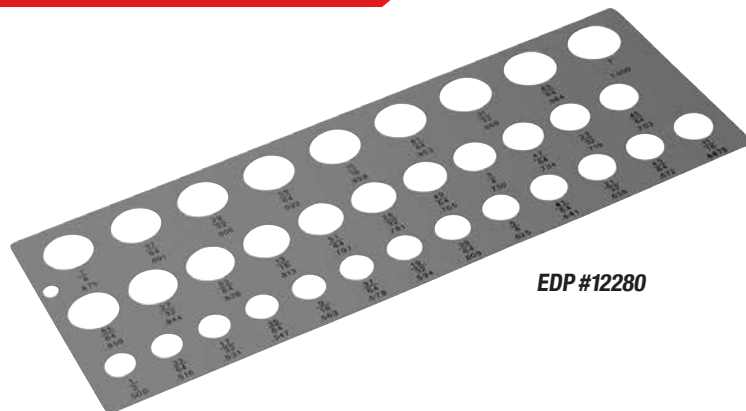

EDP #12280

Aerosol Can & Spray Bottle Racks



EDP #14757 Can Rack

The Can Rack easily mounts just about anywhere. Oils, aerosols, cleaners and “whatever” conveniently within your reach.



EDP #14760

Holds larger (24 oz.) spray bottle and cans with a 3.5" diameter hole. Reduces refill trips by accommodating larger bottles of sprays, liquids and lubricants.



EDP #90332



EDP #14758

EDP#	Description
90332	Double hole stainless steel spray bottle holder
90333	Single hole stainless steel spray bottle holder
14752	Double hole spray bottle holder in flat black
14758	Triple hole spray bottle holder in flat black
14760	Single hole spray bottle holder in flat black

Hand Sanitizer/Soap Bottle Holder



EDP #14707

Proper hygiene practices keep all employees safe and healthy. Prevent outbreaks in your facility by providing convenient, sanitary cleansing locations throughout the premises. Clean hands are critical to containing germs that spread easily.

- Mounts directly to wall to provide stability
- Adjustable for large and small bottles
- Fits round and oval shaped bottles
- Top bracket fits over bottle pump collar
- Wing nuts secure bottle firmly in rack
- 18 gauge steel construction
- Scratch proof powder coating
- Dispenses fluid directly into hands
- Bottom lip provides bottle stability
- Adjusts from 4¼" to 7¾" in height

Wipes Bucket Holder



EDP# 14768

- Holds buckets up to 5.25" in diameter
- Ideal for hand or disinfectant wipes
- Mounts directly to wall for easy access
- Unbreakable steel construction
- Textured black finish
- Multiple mounting points for added stability
- Ideal with Huot spray bottle and paper towel holders
- Made in USA

Magnetic Industrial Paper Roll Holder

EDP #14709

Our spray bottle and can racks have been extremely popular; the natural next step was to provide a holder for industrial size paper towel rolls. These magnetic holders put the paper towels right where you need them with the spray bottles.

- Extremely strong magnets provide stability
- Each magnet provides 45 lbs. of slide force
- Phenolic knobs fit any middle roll
- Steel construction with powder coating
- Use for any width or height of paper roll
- Mount rolls horizontally or vertically
- Ideal for machine cells or bathrooms
- Helps with good hygiene and cleanliness
- Keep hands and work surfaces clean
- Ideal for 5S applications



Direct Mount Adjustable Paper Roll Holder

EDP #14708

In an effort to keep employees in your facility safe and healthy, you can never have too many spray bottles or paper towels around. With so many people tearing towels off the dispenser all day, you need a good, industrial quality paper roll holder that won't break.

- Mounts directly to wall to provide stability
- Holds paper rolls horizontally or vertically
- Phenolic knobs fit any middle roll
- Holds paper rolls up to 11" wide
- Magnet adjusts paper size and tear tension
- 18 gauge steel construction
- Scratch proof powder coating
- Ideal for public areas or machine cells
- Use with Huot spray bottle racks
- 11 1/8" W x 5" D x 4 1/2" H

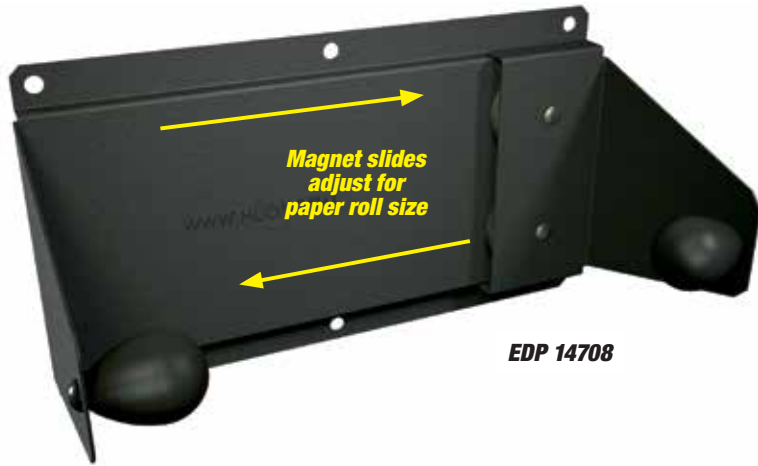

Webbing



- Woven of tough, flexible and stretchable polyethylene
- Great protection for delicate edges of cutting tools
- Doubles/triples storage capacity of any drawer

EDP#	Description	Length
14025	For 1/4" to 1/2" or 1/2" to 1" diameter tools	50'
14026	For 1/4" to 1/2" diameter tools	100'
14027	For 1/2" to 1" diameter tools	100'
14028	For 1" to 1 1/2" diameter tools	50'
14047	For 1 1/2" to 2" diameter tools	50'
14048	For 2" to 2 1/2" diameter tools	50'
14049	For 2 1/2" to 3" diameter tools	50'
14050	For 3" to 4" diameter tools	50'
14051	For 4" to 5" diameter tools	50'

- Reusable. Slips on and off easily. Elasticity assures snug fit and non-slip grip
- Easily cuts to any length
- Inexpensive protection

CNC Toolholder Identification

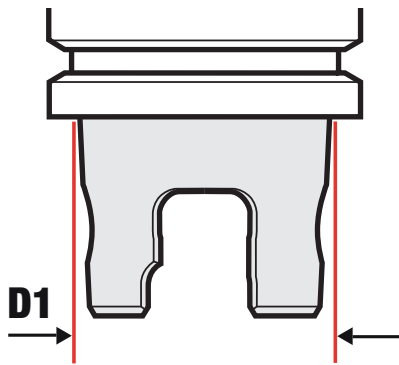

KM™ toolholders have two angled holes through the shank called “ball tracks” which act as a clamping mechanism.

KM™	
Size	D1
32	0.945 (24)
40	1.181 (30)
50	1.575 (40)
63	1.969 (50)
80	2.52 (64)

KM Registered Trademark Kennametal

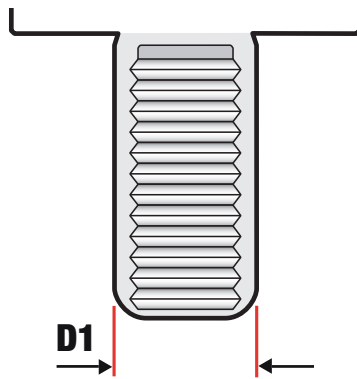

VDI toolholders come in many different shapes and sizes. One distinctive feature is the shaft is serrated on one side as shown in the illustration.

VDI Type	
Size	D1
25	0.983 (25)
30	1.181 (30)
40	1.575 (40)
50	1.969 (50)
60	2.362 (60)

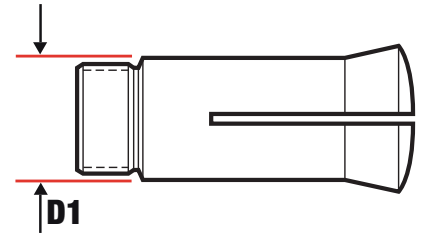

C series/3J/R8 collets have a narrow cylindrical body and a short tapered head.

C Series/3J/R8 Collets		
Size	D1	Length
5C	1.250	3.281
16C	1.889	4.312
20C	2.378	6.250
25C	2.930	6.480
3J	2.000	3.750
R8	.950	4.000

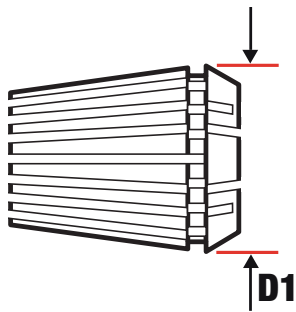

ER/RD/DR collets have a single shallow angled taper.

ER/RD/DR Collets		
Size	D1	Length
8	0.335	0.531
11	0.435	0.709
12	0.472	0.768
16	0.669	1.063
20	0.827	1.22
25	1.024	1.378
32	1.299	1.575
40	1.614	1.811
50	2.047	2.362

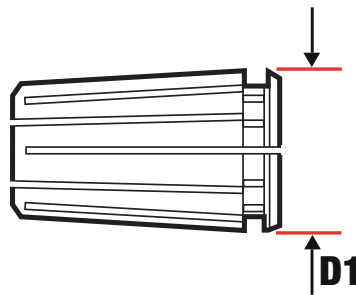

TG collets, short for tremendous grip, have a single shallow-angled taper similar to ER/RD/DR collets, but the difference between the types can be discerned by comparing dimensions.

TG Collets		
Size	D1	Length
TG50	0.76	1.438
TG75	1.062	1.844
TG100	1.379	2.375
TG150	2.001	3
TG200	2.671	3.25

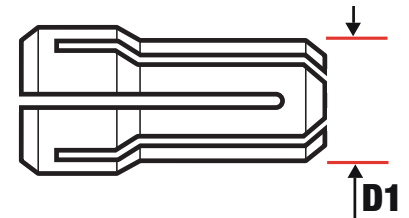

DA is short for double angle which refers to the two short angles which hold the tool in place.

DA Collets		
Size	D1	Length
DA100	0.769	1.44
DA180	1.035	1.62
DA200	0.539	1.18
DA300	0.375	1.08
DA400	1.455	2
DA500	2.255	2

Information and dimensions provided were compiled from multiple sources including but not limited to the following: "HSK Overview." Guhring The Tool Company. Guhring, Inc., n.d. Web. 31 May 2012. <<http://www.guhring.com/PS/Toolholders/Overview.htm>>. • Kennametal. Kennametal Inc., n.d. Web. 31 May 2012. <http://www.kennametal.com/en-US/home.jhtml?_requestid=904656>. • "Spindle Tooling for Manual and CNC Lathes." Hardinge. Hardinge Inc., 03 May 2010. Web. 31 May 2012. <http://www.hardinge.com/usr/pdf/collet/2348F_LR.pdf>. • Stovner, Steve. "Machine Tool Shanks (Tapers)." Tools-n-Gizmos, n.d.. Web. 31 May 2012.

CNC Toolholder Identification

When ordering Huot products it is important to determine what type and size toolholder you possess. Compare your toolholder to those illustrated, measure the D1 dimension and compare that to the dimension charts. The information and dimensions displayed are for part identification purposes only. Dimensions shown in (parentheses) are in millimeters, all others are in inches.

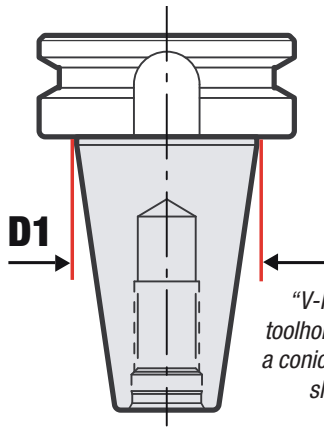

"V-Flange" toolholders have a conical tapered shank.

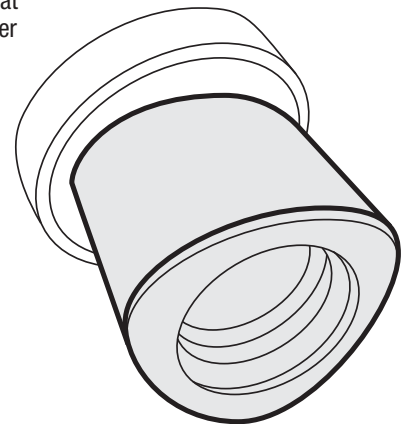

CAPTO™ including C4, C5, C6, and C8 are distinctively known for their tapered polygon shape as shown.

CAPTO Registered Trademark Sandvik Corp.

V-Flange Style				
Size	BT	CV (CAT)	DV	NMTB
25	N/A	N/A	N/A	N/A
30	1.25	1.25	1.25	1.25
32	N/A	N/A	N/A	N/A
35	1.5	N/A	N/A	N/A
40	1.75	1.75	1.75	1.75
45	2.25	2.25	2.25	N/A
50	2.75	2.75	2.75	2.75
60	N/A	4.25	N/A	N/A

CAPTO	
Size	D1
C3	(22)
C4	(28)
C5	(35)
C6	(44)
C8	(55)

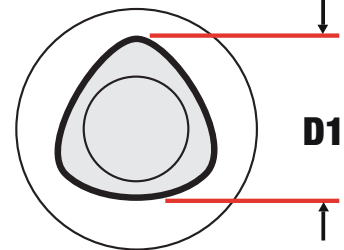

HSK Style						
Size	HSK A	HSK B	HSK C	HSK D	HSK E	HSK F
25	N/A	N/A	N/A	N/A	0.748 (19)	N/A
30	N/A	N/A	N/A	N/A	N/A	N/A
32	0.945 (24)	N/A	0.945 (24)	N/A	0.945 (24)	N/A
35	N/A	N/A	N/A	N/A	N/A	N/A
40	1.181 (30)	0.945 (24)	1.181 (30)	0.945 (24)	1.181 (30)	N/A
45	N/A	N/A	N/A	N/A	N/A	N/A
50	1.496 (38)	1.181 (30)	1.496 (38)	1.181 (30)	1.496 (38)	1.181 (30)
60	N/A	N/A	N/A	N/A	N/A	N/A
63	1.89 (48)	1.53 (39)	1.89 (48)	1.53 (39)	1.89 (48)	1.53 (39)
80	2.362 (60)	1.89 (48)	2.362 (60)	1.89 (48)	N/A	N/A
100	2.952 (75)	2.362 (60)	2.952 (75)	2.362 (60)	N/A	N/A
125	3.780 (96)	2.952 (75)	N/A	N/A	N/A	N/A
160	4.724 (120)	3.740 (95)	N/A	N/A	N/A	N/A

HSK's have a short hollow taper and we have identified 6 different styles.

See website for more sizes.

Huot Part Number Index

PART#	PG#	LIST EA	PART#	PG#	LIST EA	PART#	PG#	LIST EA	PART#	PG#	LIST EA	PART#	PG#	LIST EA	PART#	PG#	LIST EA
10200	32		13000	24		13680	6		14050	38		14784	21		16800	9	
10350	32		13015	24		13684	6		14051	38		14785	21		16930	5	
10400	32		13025	24		13685	6		14060	30		14786	21		16940	5	
10450	32		13030	24		13686	6		14130	6		14790	23		16950	5	
10500	32		13040	24		13688	6		14134	6		14791	21		16964	5	
10550	32		13050	24		13700	29		14135	6		14800	20		16970	5	
10600	32		13060	24		13773	4		14136	6		14801	20		16980	5	
10760	34		13075	24		13774	4		14164	6		14802	20		16984	5	
10761	34		13080	24		13775	4		14170	6		14803	20		16985	5	
10762	34		13085	27		13776	4		14175	6		14804	20		16986	5	
10763	34		13090	25		13778	4		14180	6		14805	20		16988	5	
10800	32		13100	24		13830	17		14185	6		14806	20		22030	23	
10875	32		13165	27		13840	17		14190	6		14810	20		22040	23	
10900	34		13166	24		13844	17		14332	18,22		14811	20		22050	23	
10950	34		13167	24		13850	17		14342	18,22		14812	20		22064	23	
11000	33		13174	30		13858	17		14352	18,22		14813	20		22070	23	
11050	33		13175	27		13860	17		14365	18,22		14816	20		22072	23	
11100	33		13180	27		13864	17		14380	18,22		14817	20		22080	23	
11150	33		13185	27		13865	17		14399	18,22		14818	20		22800	23	
11200	33		13190	27		13870	17		14600	23		14819	20		22816	23	
11250	33		13200	26		13880	17		14625	23		14820	20		22820	23	
11300	34		13300	29		13884	17		14650	20		14821	20		22825	23	
11350	34		13309	4		13885	17		14651	20		14822	20,22		22832	23	
11375	34		13321	30		13886	17		14652	20		14823	22		23830	17	
11400	34		13325	29		13888	17		14653	20		14824	22		23840	17	
11450	34		13333	30		13890	17		14654	20		14825	22		23850	17	
11500	34		13350	26		13893	17		14655	20		14826	22		23864	17	
11525	34		13375	28		13894	17		14656	20		14827	20		23870	17	
11550	33,34		13400	28		13914	4		14657	20		14828	22		23880	17	
11600	34		13409	4		13915	4		14658	20		14830	22		23884	17	
11650	34		13410	26		13916	4		14659	20		14833	22		23885	17	
11655	32		13415	26		13930	3		14702	22		14834	22		23886	17	
11700	33		13420	26		13940	3		14707	37		14840	22		23940	7	
11750	33		13425	26		13949	3		14708	38		14844	22		23950	7	
11800	33		13430	26		13950	3		14709	38		14850	22		23964	7	
11825	33		13450	28		13955	3		14725	23		14856	22		23970	7	
11850	35		13500	24		13960	3		14728	23		14857	22		23980	7	
11875	36		13509	4		13962	4		14730	23		14858	22		23984	7	
11900	35		13525	31		13963	4		14740	21		14860	17		23985	7	
11975	35		13527	31		13964	4		14741	21		14863	22		23986	7	
11985	36		13530	31		13965	3		14742	21		14865	4,17		24860	17	
12000	32		13550	24		13968	4		14743	21		14866	22		30000	28	
12050	32		13560	25		13970	3		14744	21		14880	22		30001	28	
12100	32		13570	25		13980	3		14745	21		14885	22		30025	28	
12125	32		13575	24		13984	3		14746	21		14899	8		30050	28	
12130	32		13580	28		13985	3		14749	23		14930	5		30550	33	
12200	32		13585	28		13986	3		14752	37		14940	5		30650	33	
12250	36		13590	25		13993	4		14757	37		14950	5		33166	9	
12260	36		13595	25		13994	4		14758	37		14964	5		33601	9	
12280	36		13597	28		14001	3		14760	37		14970	5		33930	6	
12300	32		13599	28		14016	3		14763	21		14980	5		33940	6	
12550	35		13600	29		14025	38		14765	23		14984	5		33944	6	
12575	35		13630	6		14026	38		14770	23		14985	5		33945	6	
12590	35		13640	6		14027	38		14771	21		14986	5		33946	6	
12600	35		13650	26		14028	38		14775	23		14988	5		33950	6	
12650	35		13652	25		14030	30		14776	21		15030	34		33964	6	
12675	35		13655	6		14047	38		14777	21		15035	34		33970	6	
12700	35		13664	6		14048	38		14780	23		15040	34		33980	6	
12750	32		13670	6		14049	38		14781	21		15235	32		50520	17	



Huot Part Number Index

PART#	PG#	LIST EA	PART#	PG#	LIST EA	PART#	PG#	LIST EA	PART#	PG#	LIST EA	PART#	PG#	LIST EA	PART#	PG#	LIST EA
50523	3		55763	14		79352	15										
50524	3		55764	14		79365	15										
50525	3		55770	14		79380	15										
50526	3		55771	14		79399	15										
50527	3		55780	14		79624	15										
50528	3		55781	14		79625	15										
50563	3		55784	14		79626	15										
55100	10		55785	14		79628	15										
55105	10		55786	14		90332	37										
55110	10		55790	14		90333	37										
55114	11		55791	14		99725	7										
55115	11		55792	14		99740	7										
55140	11		55797	14		99750	7										
55150	11		55930	12		99760	7										
55155	11		55940	12		99764	7										
55164	11		55950	12		99770	7										
55170	11		55964	12		99780	7										
55173	11		55970	12		99784	7										
55174	11		55980	12		99785	7										
55176	11		55984	12		99786	7										
55180	11		55985	12		99788	7										
55183	11		55986	12		99940	8										
55184	11		55988	12		99950	8										
55185	11		56740	21		99960	8										
55186	11		56744	21		99964	8										
55188	11		56745	21		99970	8										
55193	11		56746	21		99980	8										
55194	11		56750	21		99984	8										
55232	11,18		56764	21		99985	8										
55242	11,18		56770	21		99986	8										
55252	11,18		56777	21		99988	8										
55265	11,18		56780	21													
55280	11,18		77030	9													
55299	11,18		77132	17													
55330	13		77142	17													
55340	13		77152	17													
55350	13		77165	17													
55364	13		77180	17													
55370	13		77199	17													
55380	13		77230	15													
55384	13		77240	15													
55385	13		77250	15													
55386	13		77264	15													
55388	13		77270	15													
55631	14		77277	15													
55641	14		77280	15													
55651	14		77300	9													
55664	14		77332	4,18													
55671	14		77342	4,18													
55681	14		77352	4,18													
55684	14		77365	4,18													
55685	14		77380	4,18													
55686	14		77399	4,18													
55730	14		78230	16													
55731	14		78235	16													
55740	14		79231	15													
55741	14		79236	16													
55750	14		79332	15													
55751	14		79342	15													

Demo Vans



Huot navigates the country with demo vans equipped with their most popular products and latest innovations. Let us come right to your shop and show you firsthand solutions for storing and organizing cutting tools and machine tool accessories. Go to our web page and click on the videos tab, then click on Huot Demo Van and enjoy the 90 second humorous and informational video. Afterwards email your address to orders@huot.com and we'll let you know when we'll be in your area.



Find us on 

Huot Manufacturing

550 North Wheeler Street
St. Paul, Minnesota 55104-1788

Phone (651) 646-1869
Order Desk (800) 832-3838
Fax (651) 646-0457
Email: orders@huot.com
www.huot.com

Industrial Code: 697764
DUNS 081330734
UPC #33603
Tax ID #41-0653132
SIC #3469
©2024 Huot Mfg.
Form 80224
Huot Manufacturing reserves the right to make changes and or improvements in design and dimensions without notice.

Distributed By: