

Mounting Your Huot WorkTable Backstop

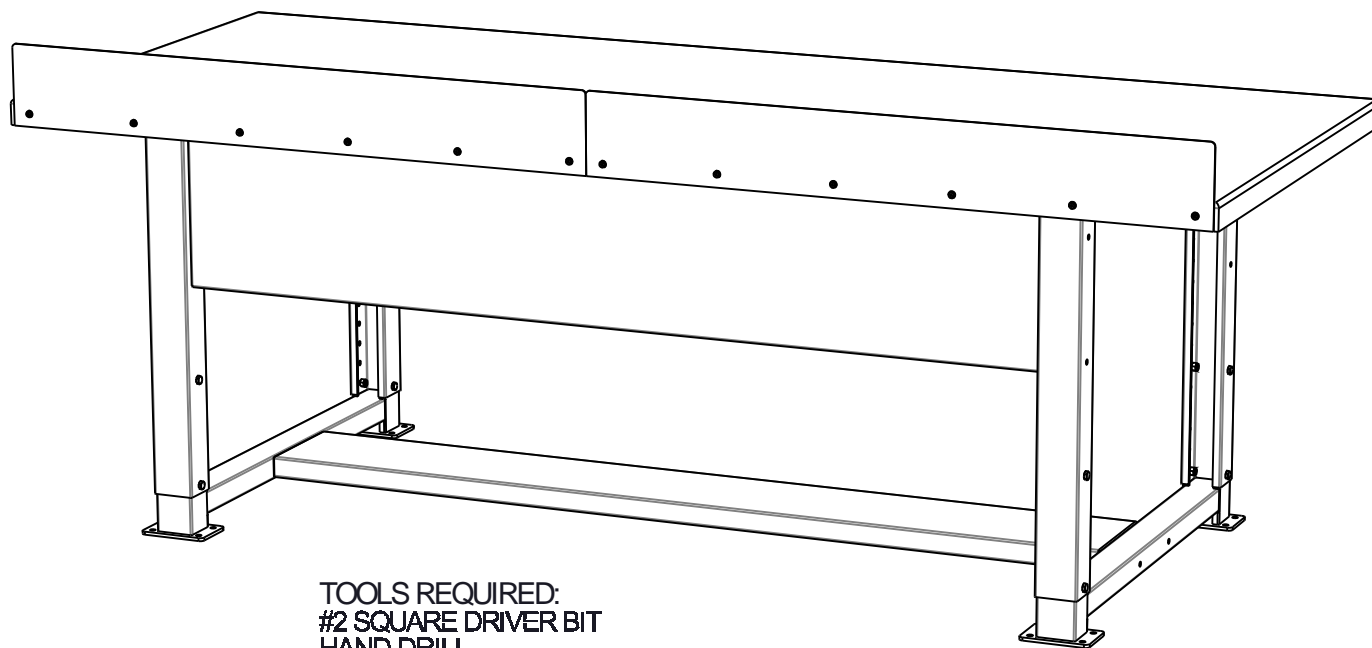

TOOLS REQUIRED:
#2 SQUARE DRIVER BIT
HAND DRILL

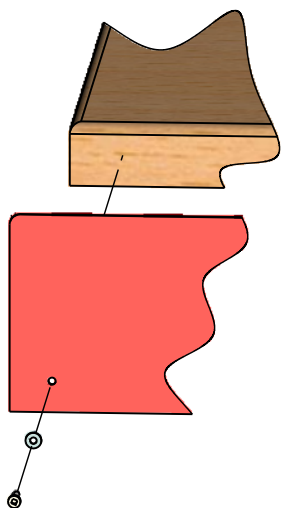
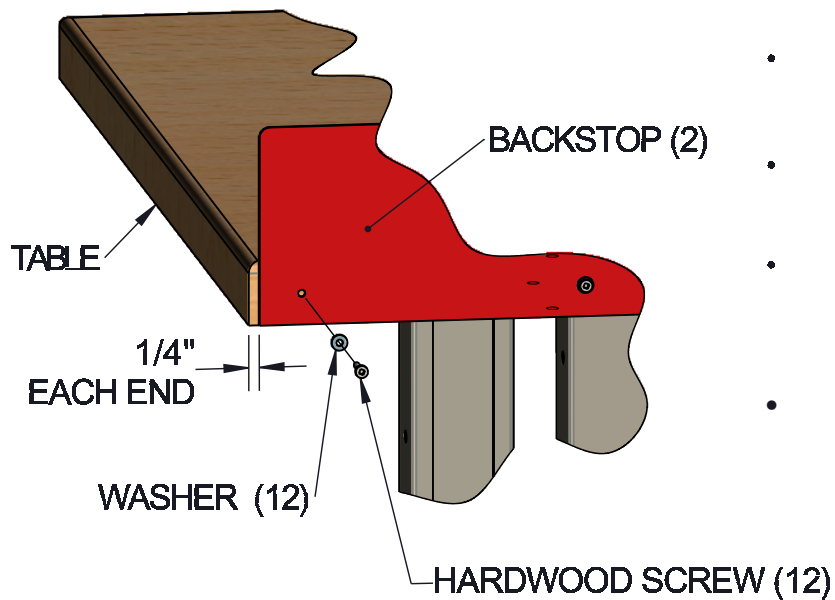

- Install the two metal backstop pieces on the back of your 72" Huot Worktable using the included fasteners as shown.
- The two metal pieces should be flush with the bottom of the wood table and inset approximately 1/4" from each end, with no gap between.
- The included screws require no pre-drilling. Simply place a washer onto a screw, then drive it into the wood with a clockwise rotation, being careful not to use excessive force or spin.
- **IMPORTANT:** USE ONLY THE SCREWS THAT ARE INCLUDED WITH YOUR BACKSTOP. OTHER SCREWS MAY DAMAGE THE WOOD TABLE TOP.



HUOT MFG. CO.
550 N Wheeler St.
St. Paul, MN 55104

Ph: (651) 646-1869
Fax: (651) 646-0457
www.Huot.com