

For ToolScoot Mounting:

For best results, check the cart for squareness as bolts are being tightened using a carpenter's square. Loosen and re-tighten the hardware as needed.

- 1) Remove 4 nuts and 4 bolts from cart bottom where shown.
- 2) Place drawer slide mounts where shown and align holes.
- 3) Loosely install 4 nuts and 4 bolts on each side as shown using the supplied hardware.

- 4) With both drawer slides extended, insert drawer between them, then attach one side at a time. First, engage the rear slide bayonette, then tilt front of drawer downward to engage the front bayonette. Repeat for the other drawer slide.
- 5) Fully insert the 2 drawer plugs as shown.
- 6) Tighten all loose nuts and bolts.

For ToolTower & TriScoot Mounting

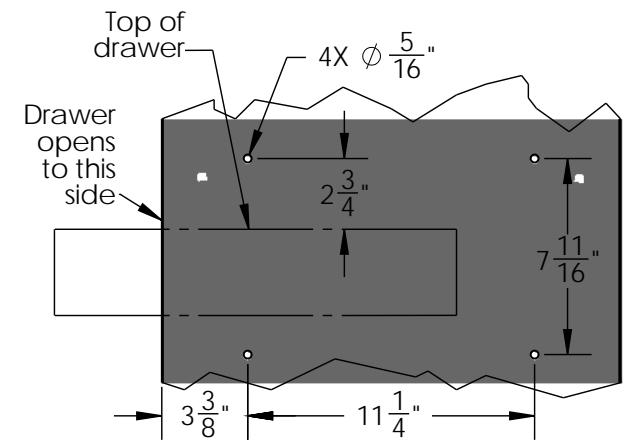

Installation on this product requires drilling 8 holes (4 on each side) per the above sketch.

- A) Determine the location for the drawer and orient the hole pattern shown for each side of the ToolTower.
- B) Drill and deburr 8 holes.
- C) For each bolt inserted, 2 washers (supplied) must be placed between the drawer slide mounts and the tooltower sides. Loosely install the drawer side mounts using 8 washers, 4 nuts, and 4 bolts on each side.
- D) Follow steps 4 through 6 (below, left).

Note: Open lid by grasping from each end.

