

Huot Tool Tower Assembly Instructions

A. Assembly instructions for 3 shelf Huot ToolTower (Important - if stacking 2 Towers see assembly instructions B).

1. Refer to drawing for list of parts to assist in assembly. Assemble entire unit BEFORE tightening nuts and bolts completely.
2. It is easiest to assemble on a table or workbench. Position sides with flanges up, on a work surface (be sure the label on side is right side up).
3. Insert one shelf into side. Insert bolts into corresponding holes, hand tighten nuts.
4. Repeat step three with remaining shelves.
5. Place the other side over the shelves with the label right side up. Insert bolts into corresponding holes and hand tighten.
6. Stand the whole unit upright. Insert screws into the remaining holes on the side and hand tighten with nuts provided.
7. Use a square to keep the shelves 90° from the sides and TIGHTEN ALL BOLTS

AND NUTS. Check all fasteners periodically to assure tightness.

B. Assembly instructions for 5 or 6 shelf Huot ToolTower with Stack Kit.

1. Position 2 black sides end to end with flanges up and labels in same direction on work surface. Insert bolts into corresponding holes where ends butt together and tighten with nuts provided.
2. Assemble all remaining parts in unit before tightening nuts and bolts completely.
3. Repeat step 3 (Assembly A) with the remaining shelves (shelf placement is variable). Be sure that when you install the center shelf you include the stack supports.
4. Repeat step 1 with the remaining 2 sides. Then place the sides over the shelves with the label right side up. Insert bolts into the corresponding holes and hand tighten with the nuts provided.
5. Finish steps 6 through 7 from assembly instructions A shown above. If any parts are missing or if you require assistance please call our toll free hotline, 1-800-832-3838.

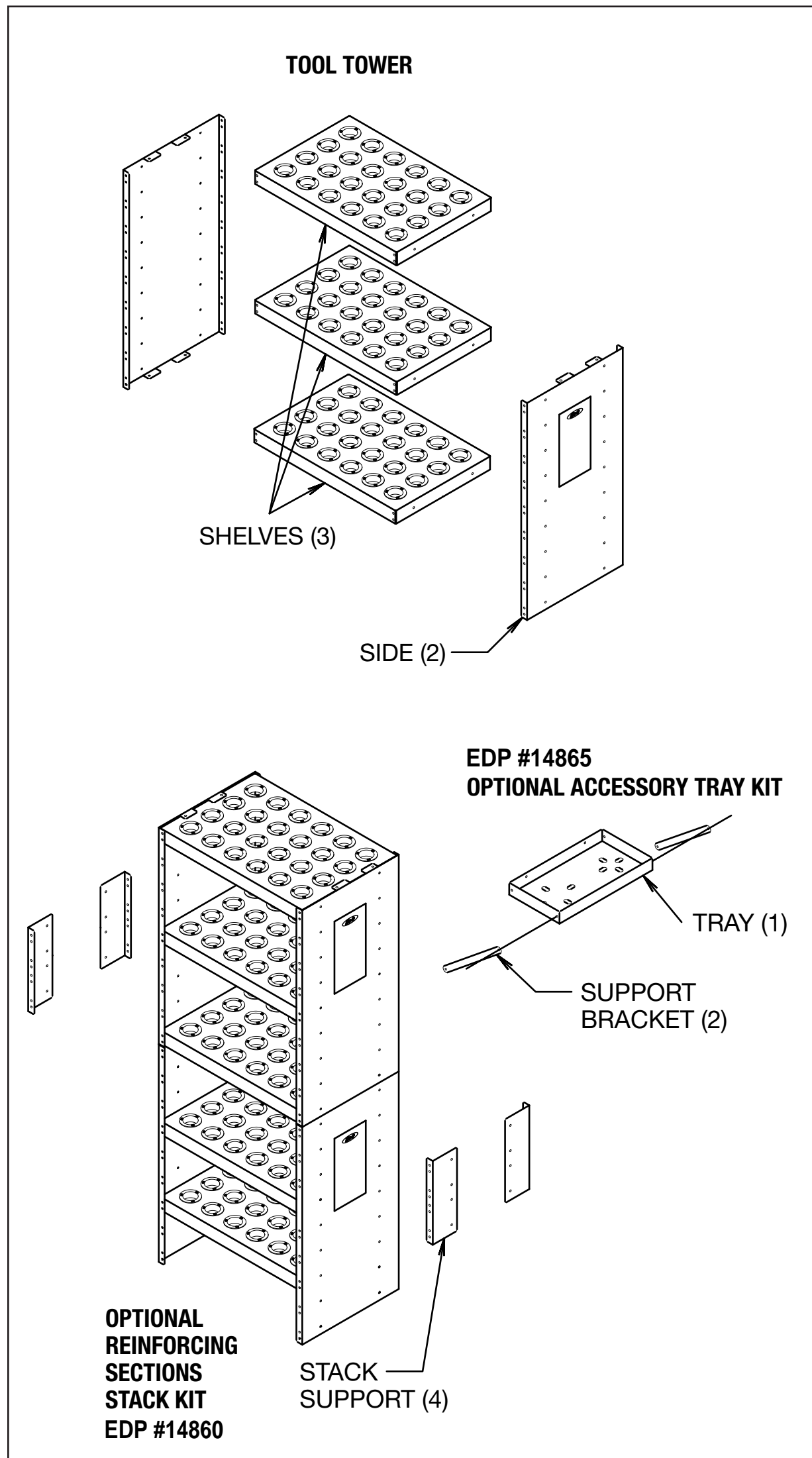

Huot Product Registration Card

Huot Item _____

Place purchased _____ Date purchased _____

Where is this unit to be used? Machine shop Tool crib Other _____

Was this item what you expected? Yes No

Overall quality Excellent Good Fair Poor

Comments _____

Business name _____

Your name _____ Occupation _____

Business address _____

City _____ State _____ Zip _____

Phone _____ Number of employees _____

Add my name to your mailing file for future cutting tool storage catalogs Yes No

Add my e-mail address for notification of new products. We do not sell or loan our list. Yes

My e-mail address is: _____



Huot Manufacturing Company

550 North Wheeler Street
St. Paul, MN 55104-1788
651.646.1869 • Fax 651.646.0457

Please register your Huot product online at www.huot.com within 10 days of purchase to validate future warranty. Click on "Warranty Registration" at the top of the home page and enter data. You can also fax (651.646.0457) or mail the form shown above for warranty registration.

Huot ToolScoot Assembly Instructions

1. Assemble entire unit BEFORE tightening nuts and bolts completely.
2. Position black bottom with the flanges up, on a flat surface.
3. Insert one side, inside bottom with the end marked TOP up. Both sides are identical. Insert screws into the corresponding holes and hand tighten with the nuts provided. Repeat this step with second side.
4. There are two possible positions for the middle angled shelf. Position the shelf into the desired position.
5. Loosely fasten (2) tray supports, to one of the trays. Place the tray, with attached supports, into position with the middle shelf. Insert bolts through the tray, side, and middle shelf (hand tighten

- bolts). Fasten tray supports to the side.
 6. Position top shelf over the sides. Fasten tray supports to remaining trays but do not tighten yet. Hold tray with supports on outside of the cart. Insert the bolts through the tray, top shelf and side. Fasten handle on opposite side.
 7. Tip the cart on its side and fasten the casters to the bottom. The swivel casters should be on the handle end. Stand cart upright and insure cart is square. TIGHTEN ALL SCREWS AND NUTS. Check all fasteners periodically to assure tightness.
 8. Slots are provided in each tray to mount a tool lock if you wish.
 9. ToolScoot is now ready to use.
- If any parts are missing or if you require assistance please call our toll free hotline, 1-800-832-3838.

